



Advanced Card Systems Ltd.
Card & Reader Technologies

ACR39U-H1 Smart Card Reader



Technical Specifications V1.03



Table of Contents

1.0.	Introduction	3
1.1.	Smart Card Reader.....	3
1.2.	Convenient and Easy to Use	3
1.3.	Ease of Integration.....	3
2.0.	Features	4
3.0.	Supported Card Types.....	5
3.1.	MCU Cards	5
3.2.	Memory-based Smart Cards.....	5
4.0.	Typical Applications	6
5.0.	Technical Specifications	7



1.0. Introduction

ACR39U-H1 is a smart card reader with a unique design. It belongs to the ACR39 family of high-speed smart card readers/writers, which has been proven to support highly demanding smart card applications. Low cost but high quality, the ACR39U-H1 creates lasting customer value and offers viable and user-friendly solutions for various smart card applications.

1.1. Smart Card Reader

ACR39U-H1 supports ISO 7816 Class A, B, and C smart cards (5 V, 3 V, and 1.8 V), microprocessor cards with the T=0 or T=1 protocol, and most memory cards in the market.

It also features a USB Full Speed interface and a smart card read/write speed of up to 600 Kbps. Highly durable, ACR39U-H1 can last for 100,000 card insertion cycles. ACR39U-H1 also has various certifications, such as EMV™ Level 1 (Contact) and PBOC (People's Bank of China), making it the ideal smart card reader for your e-Banking and e-Payment application needs.



1.2. Convenient and Easy to Use

Built with the “Bridge Desktop” casing, ACR39U-H1 allows upright insertion of smart cards, making it convenient for users to use it for applications like network security and electronic payment system makes it the ultimate smart card peripheral for computer-based environment.

1.3. Ease of Integration

ACR39U-H1 is easy to install, use, and integrate in a computer-based environment. It is PC/SC and CCID-compliant, and its drivers are compatible with operating systems such as Windows®, Linux® and Mac OS®. In addition, ACR39U-H1 can also be used on mobile devices running the Android™ platform with versions 3.1 and later.

With its various features, ACR39U-H1 can be used in numerous operations such as e-Banking and e-Payment, Physical and Logical Access Control, Transportation, and e-Government applications.



2.0. Features

- USB Full Speed Interface
- USB Type A Connector
- Plug and Play – CCID support brings utmost mobility
- Smart Card Reader:
 - Contact Interface:
 - Supports ISO 7816 Class A, B and C (5 V, 3 V, 1.8 V) cards
 - Supports CAC (Common Access Card)
 - Supports SIPRNET Card
 - Supports J-LIS card
 - Supports microprocessor cards with T=0 or T=1 protocol
 - Supports memory cards
 - Supports PPS (Protocol and Parameters Selection)
 - Features Short Circuit Protection
- Application Programming Interface:
 - Supports PC/SC
 - Supports CT-API (through wrapper on top of PC/SC)
- Supports Android™ 3.1 and later¹
- Compliant with the following standards:
 - EN 60950/IEC 60950
 - ISO 7816
 - EMV™ Level 1 (Contact)
 - PC/SC
 - CCID
 - CE
 - FCC
 - WEEE
 - RoHS 2
 - REACH
 - TAA (USA)
 - J-LIS (Japan)
 - VCCI (Japan)
 - PBOC (China)
 - Microsoft® WHQL

¹ Uses an ACS-defined Android Library



3.0. Supported Card Types

3.1. MCU Cards

ACR39U-H1 operates with ISO 7816 MCU card following either the T=0 or T=1 protocol. It also works with CAC cards, ideal for US PIV and PKI applications.

3.2. Memory-based Smart Cards

ACR39U-H1 works with several memory-based smart cards such as:

- Cards following the I2C bus protocol (free memory cards) with maximum 128-byte page with capability, including:
 - Atmel®: AT24C01/02/04/08/16/32/64/128/256/512/1024
 - SGS-Thomson: ST14C02C, ST14C04C
 - Gemplus: GFM1K, GFM2K, GFM4K, GFM8K
- Cards with intelligent 1 KB EEPROM with write-protect function, including:
 - Infineon®: SLE4418, SLE4428, SLE5518 and SLE5528
- Cards with intelligent 256-byte EEPROM with write-protect function, including:
 - Infineon®: SLE4432, SLE4442, SLE5532 and SLE5542



4.0. Typical Applications

- e-Government
- e-Banking and e-Payment
- e-Healthcare
- Public Key Infrastructure
- Network Security
- Access Control
- Loyalty Program

5.0. Technical Specifications

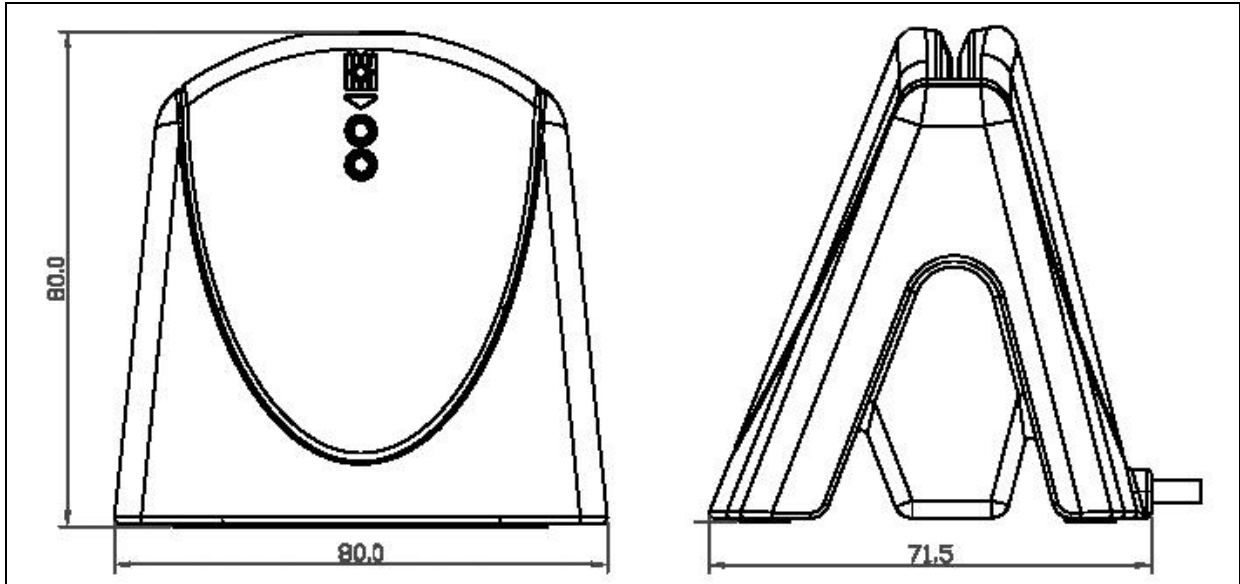

Physical Characteristics

Dimensions	71.5 mm (L) × 80.0 mm (W) × 80.0 mm (H)
Weight	174 g (± 5 g allowance for cable)
Color	White

USB Host Interface

Protocol	USB CCID
Connector Type	Standard Type A
Power Source	From USB port
Speed	USB Full Speed (12 Mbps)
Supply Voltage	5 V
Cable Length	1.5 m, Fixed

Contact Smart Card Interface

Number of Slot	1 Full-sized Card Slot
Standard	ISO 7816 Parts 1-3, Class A, B, C (5 V, 3 V, 1.8 V)
Protocol	T=0; T=1; Memory Card Support
Supply Current	Max. 50 mA
Smart Card Read/Write Speed	9.6 Kbps - 600 Kbps
Short Circuit Protection	(+5) V/GND on all pins
Clock Frequency	4.8 MHz
Card Connector Type	Contact
.....	Landing (optional)
Card Insertion Cycles	Min. 100,000
.....	Min 200,000 (for landing connector)

Built-in Peripheral

LED	2 single-color: Green and Red
-----------	-------------------------------

Application Programming Interface

PC-linked Mode	PC/SC
.....	CT-API (through wrapper on top of PC/SC)

Operating Conditions

Temperature	0 °C – 60 °C
Humidity	Max. 90% (non-condensing)
MTBF	500,000 hrs

Certifications/Compliance

EN 60950/IEC 60950, ISO 7816, USB Full Speed, EMV™ Level 1 (Contact), PC/SC, CCID, CE, FCC, WEEE, RoHS 2, REACH, TAA (USA), J-LIS (Japan), VCCI (Japan), PBOC (China), Microsoft® WHQL



Device Driver Operating System Support

Windows® XP, Windows Vista®, Windows® 7, Windows® 8, Windows® 8.1, Windows® 10
Windows® Server 2003, Windows® Server 2008, Windows® Server 2008 R2, Windows® Server 2012,
Windows® Server 2012 R2, Windows® Server 2016
Linux®, Mac OS®, Android™ 3.1 and later



Android is a trademark of Google Inc.
Atmel is registered trademark of Atmel Corporation or its subsidiaries, in the US and/or other countries.
EMV is a registered trademark of EMVCo LLC in the United States and other countries.
Infineon is a registered trademark of Infineon Technologies AG.
Linux® is the registered trademark of Linus Torvalds in the U.S. and other countries.
Mac OS is a trademark of Apple Inc., registered in the U.S. and other countries.
Microsoft, Windows and Windows Vista are registered trademarks of Microsoft Corporation in the United States and/or other countries.