

# T5Pro / T5 / T5s

## Series user manual

(★ mark for special model function)

Specific function subject to actual attendance

If there is an update are subject to change without notice

## **Preface**

Honorable customers,

Thanks for choosing products of this company. T5Pro/T5/T5S, with world cutting edge technologies—fingerprint recognition, computer communication, as well as microelectronics, is considered to be combination of three technologies: electronics, optics and computer communication. It is no doubt that it has become the first choice of standalone time & attendance for enterprises with its strong function and veracity. Please read this user manual carefully to have an initial understanding of functions and basic knowledge of installation, debugging, maintenance, application and management to better use this product.

Utilizing the state-of-the-art biometric tech, this product will bring unprecedented reliability, convenience and benefits to the top management of enterprise in HR.

# Contents

1	Product Introduction .....	2
1.1	Introduction.....	2
1.2	Modle .....	2
1.3	Size .....	3
2	Operation Guide .....	5
2.1	Interface Introduction.....	5
2.2	Upper Electricity .....	5
2.3	Register User .....	5
2.3.1	Register User's Fingerprint.....	5
2.3.2	Register User's Card.....	6
2.3.3	Register Card + Fingerprint.....	7
2.4	Delete users .....	7
2.4.1	Delete user's fingerprint.....	7
2.4.2	Delete user's card / card + fingerprint .....	8
2.5	Function button.....	8
2.6	Register Management Cards.....	9
2.7	Illustration for pressing fingerprint .....	9
2.8	Usage Notice.....	9
3	System Installation .....	12
3.1	Running Environment.....	12
3.2	System Installation .....	12
3.3	Uninstall the software .....	15
4	Communication .....	17
4.1	Login the System.....	17
4.2	T5Pro/T5/T5S Management.....	18
4.2.1	Add Unit  .....	18
4.2.2	Modify Unit .....	20
4.2.3	Delete Unit .....	21
4.2.4	Synchronize Time.....	21
4.2.5	Initialize Unit.....	21

4.2.6	Terminal Parameter Settings★	21
4.2.7	Download New Records	23
4.2.8	Download All Records	23
4.2.9	Clear record	23
4.2.10	Backup Employees	23
4.2.11	Resume Employees	24
4.2	Record Supervision	24
4.2.1	Activate Real-time	25
4.2.2	Prohibit real-time	25
4.3	Employees Management	26
4.3.1	Add Employee	26
4.3.2	Modify Employee	29
4.3.3	Delete Employee	29
4.3.4	Transfer Department	29
4.3.5	Set Privilege	30
4.3.6	Copy Privilege	31
4.3.7	Download FP	31
4.3.8	Upload Employee & FP	32
4.3.9	Delete employee from Unit	32
4.3.10	Check Staff	33
4.3.11	Department Management	33
4.3.12	Right-hand Button	34
4.4	Record Management	34
4.4.1	Search Record	35
4.4.2	Export record	36
4.5	System Settings	36
4.5.1	Basic parameter setting★	37
4.5.2	T&A Status setting	37
4.5.3	Timing downloading record	38
4.5.4	Management PW setting	38
4.5.5	Database linking setting	39
4.5.6	Exit system	40

4.6	Software Interface Setting .....	41
4.6.1	Interface Skin Color.....	41
4.6.2	Language .....	41
4.6.3	Setting Quick Access Button .....	41
5	Background Management .....	43
5.1	Login System .....	43
5.2	System .....	44
5.2.1	Parameters Settings.....	44
5.2.2	Administrators .....	47
5.2.3	Administrator's Password Set .....	48
5.2.4	Modified Record Log .....	48
5.2.5	Managing Log .....	49
5.2.6	Set Database Link.....	50
5.2.7	Exit System .....	51
5.3	HR Management .....	51
5.3.1	Department Management.....	51
5.3.2	Employees Maintenance .....	52
5.4	Attendance Management .....	55
5.4.1	Holiday List.....	55
5.4.2	Timetable and Shift.....	56
5.4.3	Employee Scheduling.....	62
5.4.4	Attendance Records.....	65
5.4.5	Attendance Calculating and Report.....	67
5.5	Deal with Exceptions .....	76
5.5.1	Away on Business/ Leave .....	76
5.5.2	Append Record .....	77
5.5.3	Append Record Collectively .....	77
5.5.4	Dealing with Collectively Late / Leaving .....	77
5.6	Data Maintenance .....	78
5.6.1	Import Employee List .....	78
5.6.2	Import Attendance Record.....	79
5.6.3	Clear Obsolete Data.....	80

5.6.4	Compress Database.....	80
5.6.5	Backup Database.....	80
5.6.6	Initialize System .....	81
5.7	External Program Management.....	81
5.7.1	Connect to Communication management software .....	81
6	FAQ .....	83
6.1	Fingerprint has been enrolled but gets failure in identification.....	83
6.2	The machine can't be connected with PC .....	83
6.3	No records found though identification have passed.....	83
6.4	The FP scanner is off and Employee can't identify.....	83
6.5	terminal beeps automatically when no one punches in/out .....	84
7	Appendix .....	86
7.1	Wiring Instruction ★ .....	86
7.2	Wiring diagram ★ .....	88

# Chapter1

## Introduction

The main theme of this chapter is the advantage of T5Pro/T5/T5S, as well as function introduction.



# 1 Product Introduction

## 1.1 Introduction

T5Pro/T5/T5S Fingerprint Reader is an innovative fingerprint card access reader which fully integrates fingerprint technology. The very compact design makes it suitable for installation on door frame.

T5Pro/T5/T5S adopt TI Stellaris® 32-Bit High Speed CPU to ensure stable and reliable. They are with compact design integration BioNANO fingerprint algorithm with infrared auto wakeup sensor optional EM RFID and Mifare card and support ISO fingerprint template.



## 1.2 Modle

Modle	Function
T5S	It is a access control slave reader, just send out fingerprint and RFID/Mifare code through the RS485 to access control system.
T5	It is an access control and time attendance terminal. Including BioNANO fingerprint algorithm can be verified fingerprint and RFID/Mifare card in itself. And support TCP/IP, Min USB communication with PC software, RS485 and Wiegand output to integrate into access control system.
T5Pro	It is standalone access controller have all T5 functions and have a relay output can direct lock control.



### 1.3 Size

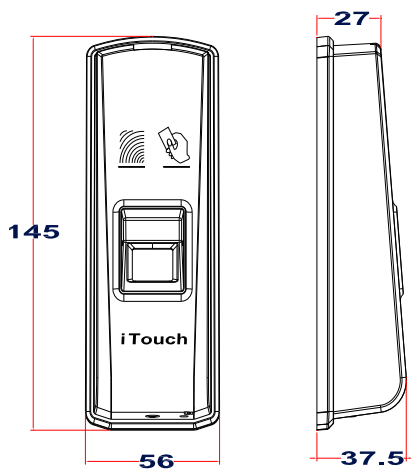

# Chapter2

## Operation Guide

This chapter is mainly about the hardware operation, contains how to set the administrator, how to add/delete users etc.



## 2 Operation Guide

### 2.1 Interface Introduction

Interface:



#### LED Indicator

Three different colors (Blue, red and green) to show

#### FP sensor

Place finger on sensor

Bottom:

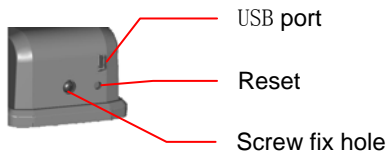

USB port



Reset

Screw fix hole

Notice: The operation will not delete any user data stored in the device.

### 2.2 Upper Electricity

DC 12V supply the power for device. Blue LED flashes fast and Fingerprint Sensor lights with beeps.

There are 4 cards in the packing: Enroll Card , Delete Card  and User Card  \* 2.

### 2.3 Register User

#### 2.3.1 Register User's Fingerprint

Firstly swipe Enroll Card, blue LED flashes quickly, enter into registration state. In time we can register the user finger.\

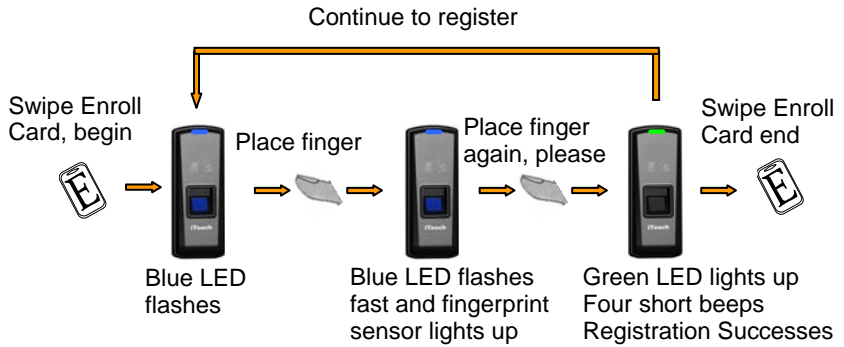

Note: If the finger has been registered, red LED flash twice and follow 2 beeps.

### 2.3.2 Register User's Card

Firstly swipe Enroll Card, blue LED flashes quickly, enter into registration state.

In time we can swipe the user card.

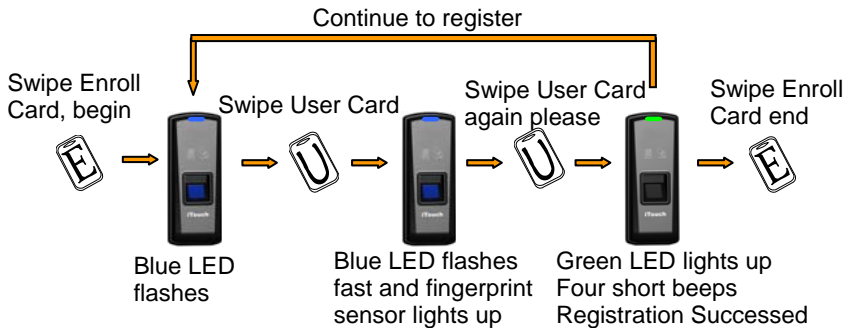

Note: If the card has been registered, red LED flash twice and follow 2 beeps.

### 2.3.3 Register Card + Fingerprint

Note: If the User Card has been registered, red LED flash twice and follow 2 beeps.

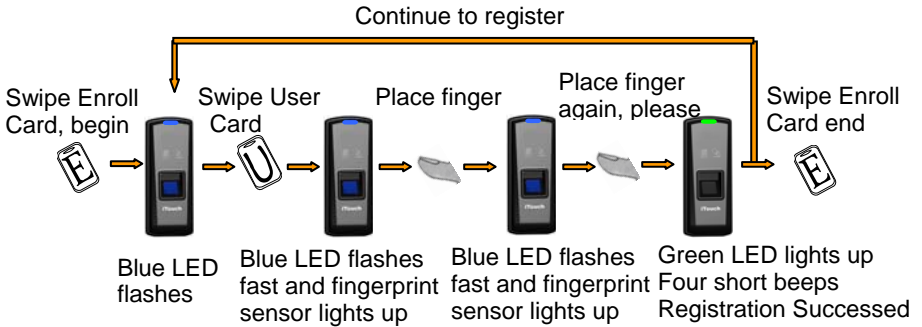

## 2.4 Delete users

### 2.4.1 Delete user's fingerprint

Firstly swipe Delete Card, red LED flashes quickly, enter into deletion state. In time we can delete the user.

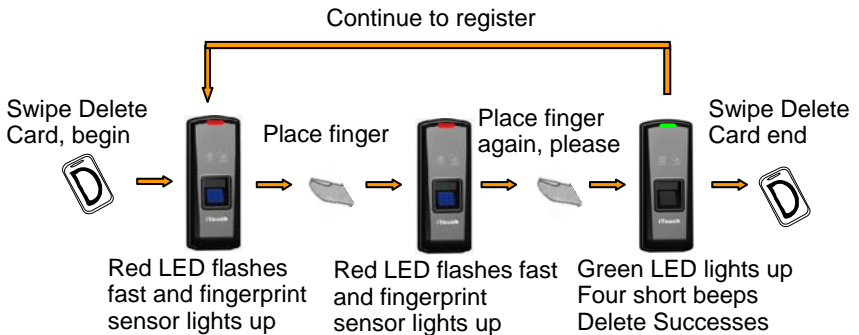

Note: If the finger has not exited in terminal, red LED flashing twice and two long beeps beep.

## 2.4.2 Delete user's card / card + fingerprint

Firstly swipe Delete Card, red LED flashes quickly, enter into deletion state. In time we can delete the user.

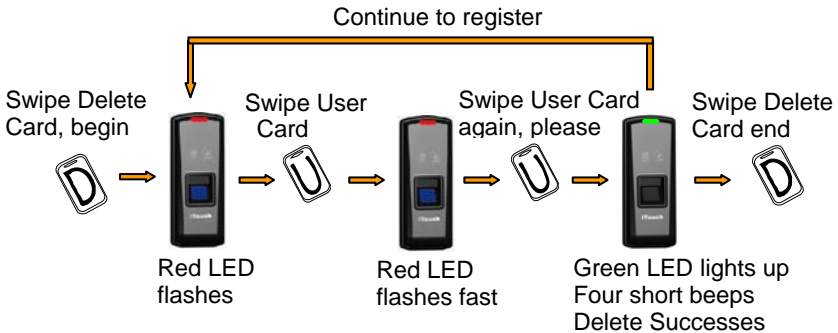

Note: If the finger has not exited in terminal, red LED flashing twice and two long beeps beep.

## 2.5 Function button

Press the button until heard beeps that eliminate Enroll Card and Delete Card information in the device. After that you must register management cards (Enroll Card and Delete Card) to run the machine.

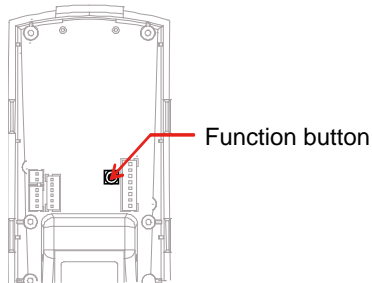

Notice: The operation will not delete any user data stored in the device.

## 2.6 Register Management Cards

Register Management Cards:(Enroll Card and Delete Card)

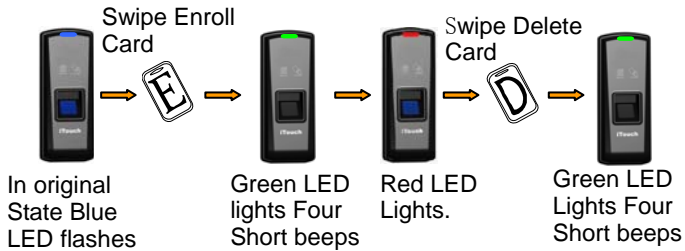

## 2.7 Illustration for pressing fingerprint

Correct method:



Wrong method:



Valid

Left

Right

Defluxion

Down

1. Please register the thumb or index finger if possible.
2. Place finger flatly and the center of the finger is on the center of scanner window and press a little hard on scanner so it can scan as large finger area as possible to extract enough minutia.
3. Keep the angle and direction of finger the same each time placing on scanner.
4. Touch the forehead to increase oily level of the finger, if the fingerprint is too dry.

## 2.8 Usage Notice

1. Don't scratch the surface of the optical fingerprint sensor with the keen-edged things such as small knife or pen.
2. Humidity, dust and direct light can affect the terminal's performance.
3. Please don't clean the surface of the optical fingerprint sensor with the

organic impregnate such as alcohol or gasoline.

Recommended solution:

Use one-sided adhesive tape to paste on the sensor and then remove the tape.



# Chapter3

# Installation

This chapter mainly discusses the installation and un-installation of software as well as the hardware and operation system requirement.



### 3 System Installation

First we should install background management software on the computer. Please refer to the following steps.

#### 3.1 Running Environment

##### **Hardware environment:**

Pentium II 266 and above; Pentium III 500 and above is recommended

128 Memory and above; Minimum 100M hardware space

COM Port

CD-ROM (CD-ROM needed in installation)

VGA support 800\*600 resolution and above

##### **Operating system:**

Microsoft Windows 2000

Microsoft Windows XP (recommended)

Microsoft Windows Vista

#### 3.2 System Installation

Insert the CD to the pc's CDROM. Following window pops up:

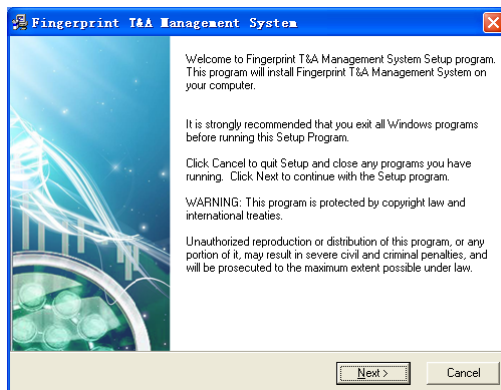

Click [Next] to continue installation (see the picture below):



Select the target directory to install the program and the default is “C:\Att”. Click [Next] to continue installation (see the picture below):

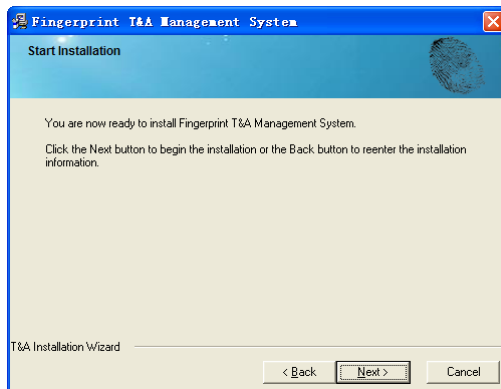

Click [Back] and installation will return to the previous screen and re-select target directory; Click [Next] and the installation will start as the following picture shows:

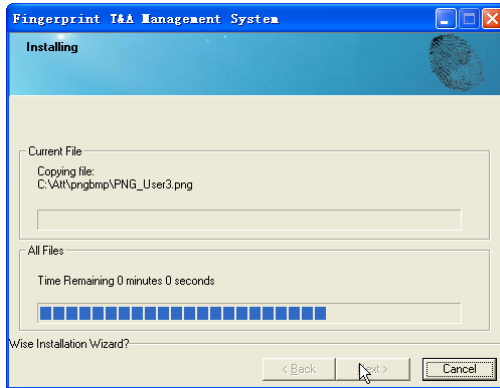

The installation will be done after seconds (see the picture below):

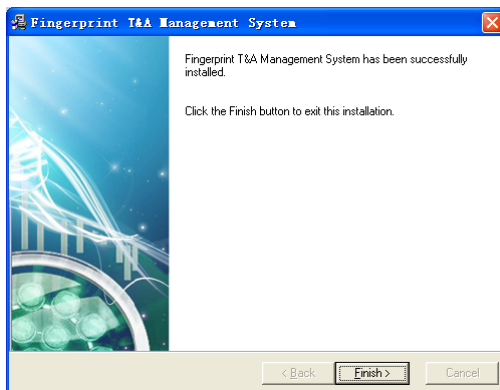

Click [Finish] to close the installation program and an icon  will be added to the desktop. Double click it and the T&A management system will be started. In addition, [T&A Management System] has been added to [All Programs]. Please see the picture below:

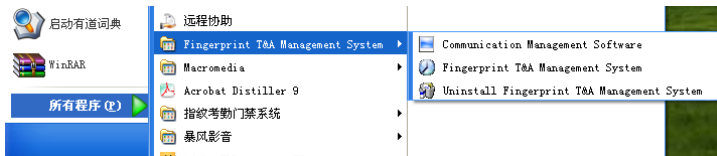

The shortcut of [Fingerpright T&A Management System] is included in [All Programs].

### 3.3 Uninstall the software

Click [Uninstall Fingerpright T&A Management System] in the above picture, click [Next] and the program will be uninstalled automatically.

Please note: All the files and data will be deleted after uninstalling the program so please make sure before operation!

# Chapter4

## Communication

The chapter is mainly regarding the link method and the communication between the machine and pc.



## 4 Communication

The communication between software and device should be connected successful.

### 4.1 Login the System

click [Start]--[All programs]--[management system] to running the software. The default login password is empty; the following window will pop up:

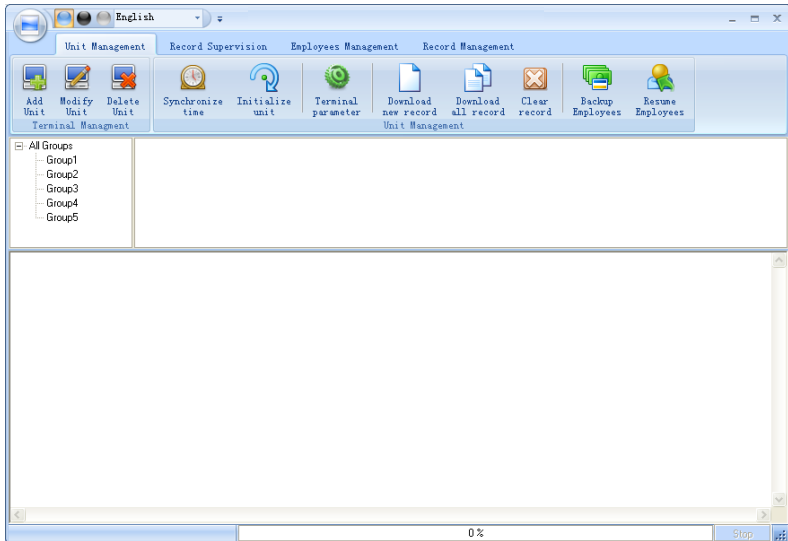

Pic4.1 Main Interface

If the time attendance software's login password is not empty, you should enter the password firstly.



Enter the password and click the button [OK] to login.

Notice: If you enter the wrong password 3 times, the software will automatically close.

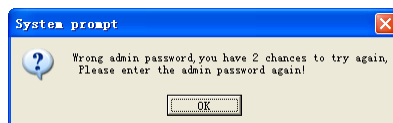

Click the button [OK]. And then try to enter the correct password.

## 4.2 T5Pro/T5/T5S Management

### 4.2.1 Add Unit★

Click the button [Add Unit]. Following windows pops up:

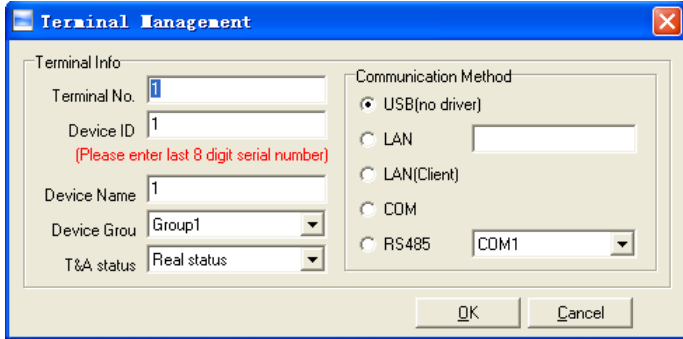

Terminal No.: This number can be set as you like.

Device ID: Please enter last 8 digit serial number.

Device Name: You can set it as you like.

Device Group: This group is used to manage the terminal machine.

T&A Status: There are three options: Actual Status, on duty and off duty. When we set it as "Actual Status" the attendance records' status in the software are as same they are in the device. If you set it as "ON Duty", all the records' status which is from this machine will be "On duty".

USB(No driver): connect pc and device using USB cable .

★ LAN: Input the terminal's IP address. The default IP address is 192.168.0.218.

★ LAN (client): Only communication with the PC which has server IP.

USB: Serial communication port.

RS485: The default COM value is COM1;

Click the button [OK] to save the information.



There will display an icon for the new added device terminal <sup>1</sup>[Front door] . Put the mouse on icon, which will show the detailed info of the device:



Machine Number: 1  
Machine Name: Front Door  
Serial Number: 1  
Communication Method: USB  
Connection State: Normal

Notice: Click right button of mouse on the device icon to show:

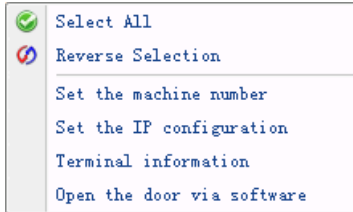

Pic4.2 Right click Terminal menu

[Select all]: select all terminals;

[Reverse selection]: reverse to select all;

[Set Device ID]: Setup device ID through software

★ [Set the IP configuration]: please follow the picture:

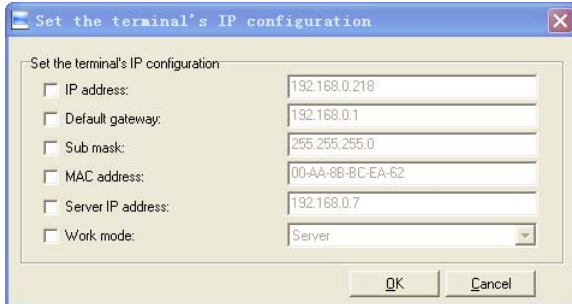

[Terminal Information]:

Display terminal information as follows:

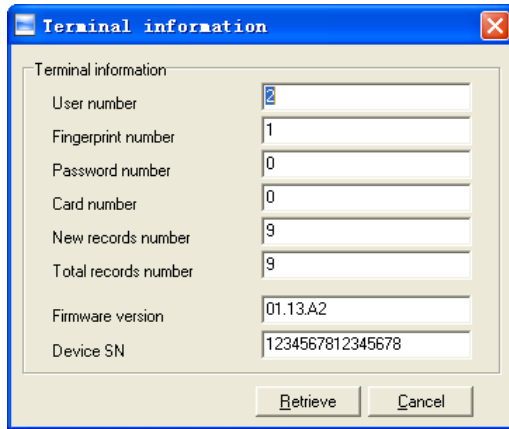

Click the button [Retrieve] to retrieve the terminal information. Click the button [Cancel] to close the window.

#### 4.2.2 Modify Unit

Choose the terminal (tick '☐' showing '√') and then click [Modify Unit]; the following window will pop up:

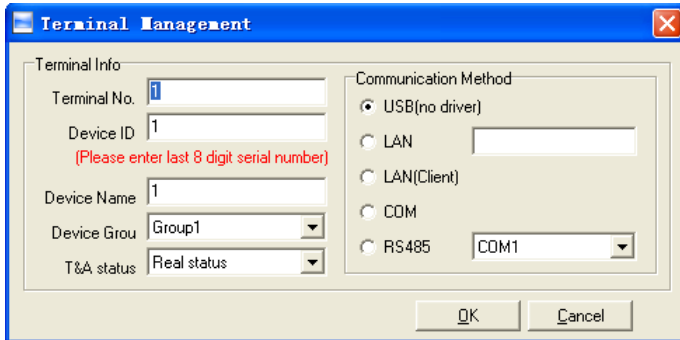

Modify the information and then click the button [OK] to save the modification. Click the button [Cancel] to cancel the modification.

If the “No” is already exist in the software, following message box pops up:

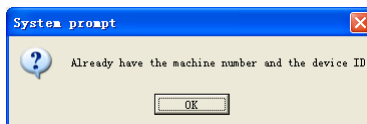

Click the button [OK] to set the Unit information again.

### 4.2.3 Delete Unit

Choose the T&A unit (tick '☐' showing '√') and then click the button [Delete Unit]. Following message box pops up:

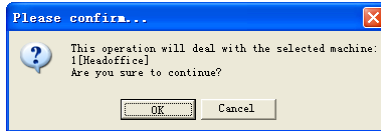

Click the button [OK] to delete or click the button [Cancel] to cancel.

### 4.2.4 Synchronize Time

Synchronize the terminal's time with the computer time. Click the button [Synchronize time]. Following message box pops up:

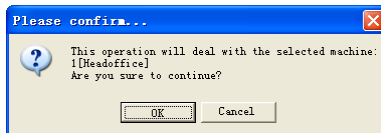

Click the button [OK] to confirm or click the button [Cancel] to cancel.

Some operation information displays in the main interface as follows:

### 4.2.5 Initialize Unit

The device will resume to factory settings. All data will be cleaned up. Attention should be taken for this operation!

Click the button [Initialize Unit]. Following message box pops up:

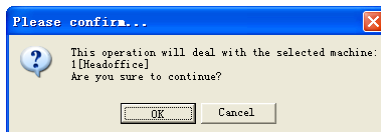

Click the button [OK] to confirm or click the button [Cancel] to cancel.

Some operation information displays in the main interface as follows:

### 4.2.6 Terminal Parameter Settings ★

Click the button [Terminal Parameter]. The [Terminal parameter settings] interface pops up:

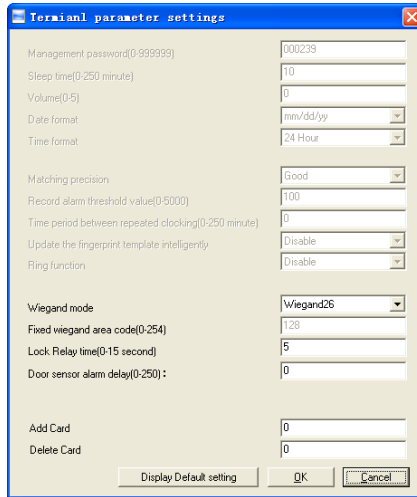

★ [Wiegand Mode]: Wiegand26, Encrypted wiegand, Fixed Wiegand and Card Number. The default is Wiegand26.

★ [Fixed Wiegand area code (0~254)]: If you upload one fingerprint to two terminals, the same fingerprint's wiegand outputs are different in the different terminals. If the two terminals' wiegand area codes are same, the same fingerprint's wiegand outputs are same in these two terminals.

★ [Lock delay]: Lock delay means since access granted, the door opens delay time (range is 0—10s).

★ [Door sensor alarm delay (0-250)]: When the door does not close within setting time, the device will alarm. (Range 0-250s) 0 means disable the Door sensor alarm.

[ADD/Delete Card]: There are four cards in the packing; Enroll Card, Delete Card and two User card. The Enroll and Delete card are management cards for device. Both of the Enroll and Delete card must exist in the device at the same time. If one card is lacking, the setting is not effective.

Click the button [OK] to save the settings. Click [Cancel] to cancel the setting.

The main interface will show like following:

```
[2011-09-30 12:17:16]Set Advanced Parameter...
[2011-09-30 12:17:17]1[1]Set the terminal status list successfully.
[2011-09-30 12:17:17]1[1]Parameter setting Successful!
```

#### 4.2.7 Download New Records

Download the records from the terminal to the computer.

Click the button [Download new records]. Following message box pops up:

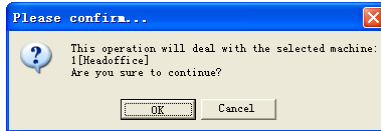

Click the button [OK] to confirm or click the button [Cancel] to cancel.

Some operation information displays in the main interface as follows:

#### 4.2.8 Download All Records

Download all records from the terminal to the computer.

Click the button [Download all records]. Following message box pops up:

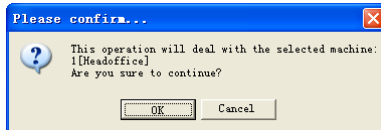

Click the button [OK] to confirm or click the button [Cancel] to cancel.

Some operation information displays in the main interface as follows:

#### 4.2.9 Clear record

Clear all records from the TERMINAL to the computer.

Click the button [Clear record]. Following message box pops up:

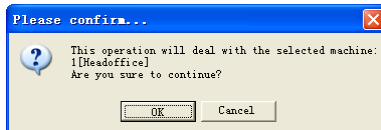

Click the button [OK] to confirm or click the button [Cancel] to cancel.

Some operation information displays in the main interface as follows:

#### 4.2.10 Backup Employees

Download the employee information and employees' fingerprint templates from the terminal to the computer. You can edit the employee information in the database Att2003.mdb. The user information is saved in the table "User Info" of the database. And the fingerprint templates information is saved in the folder "Template" in the

installation directory.

Click the button [Backup Employee]. Following message box pops up:

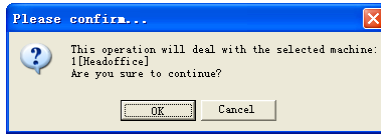

Click the button [OK] to confirm or click the button [Cancel] to cancel.

After backup employee info completed, it starts to backup fingerprints. When backup completed, the whole backup process is finished. The main interface is following:

#### 4.2.11 Resume Employees

Upload the employee information and employee's templates from the computer to the terminal.

Click the button [Resume Employees]. Following message box pops up:

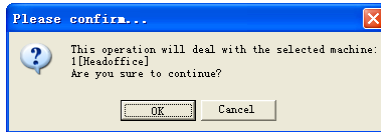

Click the button [OK] to confirm or click the button [Cancel] to cancel.

Some operation information displays as follows:

Notice: Before resume operation, each employee should be set terminal authority. If the employee doesn't not added to device terminal, the following message will prompt,

#### 4.2 Record Supervision

Get the records from the terminal real-time.

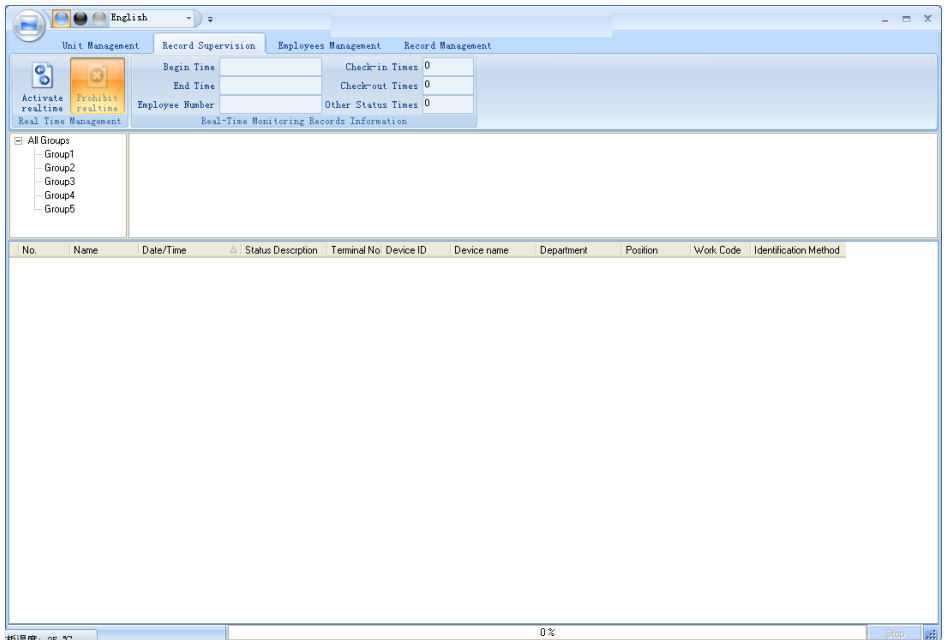

#### 4.2.1 Activate Real-time

Click the [Activate real-time] button, the status bar shows message: Reading attendance records...

Now the software is beginning to supervise the terminal, and then collect the records every 5 seconds.

When the employee clock in or out, the [Check-in Times] or the [Check-out times] increases one. And the real time record shows.

And the following window which includes the employee ID, Name, Department and Position pops up:



#### 4.2.2 Prohibit real-time

Click the button [Prohibit real-time] to stop the real-time monitoring. You can see the begin time and end time of the real-time monitoring in the [Real-Time Monitoring

## Records Information]

### 4.3 Employees Management

Employees management mainly includes these functions: employee management in database of local PC、employee communication management between PC and unit、employee info tracking.

Employee management interface is as following,

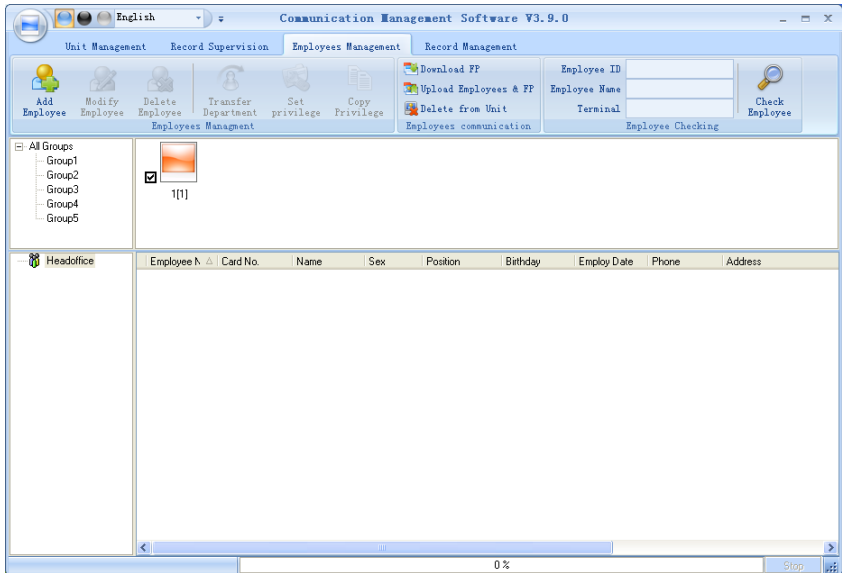

#### 4.3.1 Add Employee

Click [Add Employee] button, open [Add/modify Employee info] window. The interface is as following:



**Add/Modify Employee Info**

Basic Info

No.

Card No.

Name

Password

Sex

Dept.

Group number

User type

Identification Method

ID No.

Birthday

Nation

Employ Date

Position

Political Feature

Education

Speciality

Phone

Mobile

Native Place

Address

[Basic info]: Edit employee's basic information.

**Add/Modify Employee Info**

Basic Info

No.

Card No.

Name

Password

Sex

Dept.

Group number

User type

Identification Method

ID No.

Birthday

Nation

Employ Date

Position

Political Feature

Education

Speciality

Phone

Mobile

Native Place

Address

[Basic info]: Edit employee's basic information.

**Notice: The No. is exclusive as well as the first digit cannot be 0!**

You can also add pictures for employee. There are two ways to add pictures:

1st way: Click  button, choose employee's picture stored in PC and open [Edit picture] window as following,

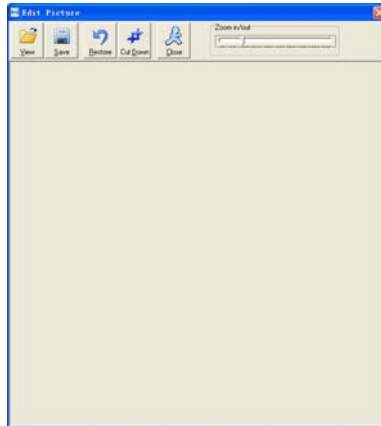

Click the button [View] to choose one photo. And Crop the photo by the [Cut-down] button and then click the button [Save] to save as follows:

No.	8108
Card No.	3356385
Name	Lizzy
Sex	Female
Dept.	head office
Group number	1
User type	Normal User
Verify Mode	Sept
ID No.	300300198401021234
Nation	Chinese
Position	
Education	
Phone	
Native Place	Shanghai
Address	
Birthdate	1984- 1- 2
Employ Date	2006-11- 9
Political Feature	Party Member
Speciality	
Mobile	

2nd way: You can install camera to take pictures and edit then save. Make sure there is camera equipment installed in your PC.

Click  button, open [Pictures shooting] window as following,

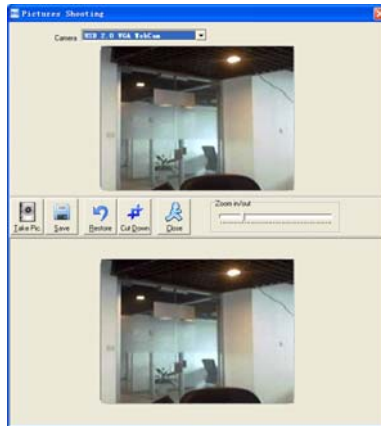

Choose camera equipment, and click the button [Take Pic] to take a photo.

Edit the photo by [Cut-down] function and then click the button [Save] to save.

Click the button [] to delete the employee photo.

#### 4.3.2 Modify Employee

Modify employee is to modify the database employee info in local PC.

Choose the employee info from employee info list and click [Modify Employee] button or double click this employee info, open [add/modify staff info] window to modify. For detail, please refer to 4.4.1[Add Employee].

#### 4.3.3 Delete Employee

Delete employee is to delete database employee info in local PC.

Choose employee from staff info list (you can choose some or one through [Shift] or [Ctrl] key), click [Delete Employee] and the following window pop-up:

Click [OK] to confirm and start to delete employee info. Click [Cancel] to exit.

#### 4.3.4 Transfer Department

When employees are transferred, there is necessary to transfer them between different departments. Transfer department enable realize this function.

Choose employee info who need to transfer department in employee info list (you can choose some or one through [Shift] or [Ctrl] key), click [Transfer department] to open [Employee transfer] window as following,



Choose the department which employee transfer to, click [OK] button to save transfer info. Click [Cancel] button to exit.

#### 4.3.5 Set Privilege

We can only upload the employee to the authorized terminal.

Choose the employee from employee info list (you can choose some or all the employee by using the button [Shift] or [Ctrl] on your computer's keypad). Click the button [Set privilege]. The [Set privilege] window pops up:

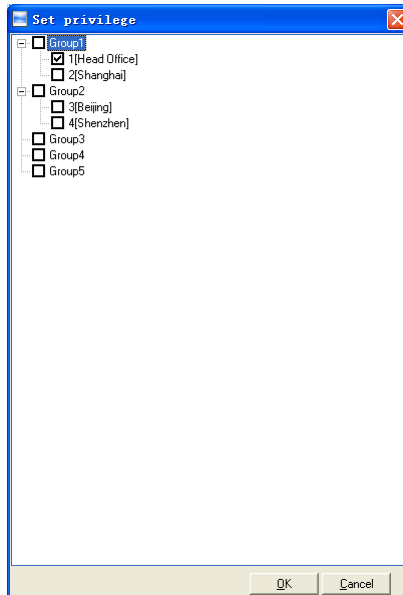

Choose the terminal and then click the button [OK] to save.

You can find the employee's authorized terminal in the column [Unit] as follows:

Employee No.	Card No.	Name	Sex	Position	Birthday	Employ Date	Phone	Address	1st FP	2nd FP	Unit
8102		Judy							<input type="checkbox"/>	<input type="checkbox"/>	1
8103		Micheal				2010-12-17			<input type="checkbox"/>	<input type="checkbox"/>	1,2
8108		Lizzy							<input type="checkbox"/>	<input type="checkbox"/>	2

Judy's fingerprint is in the unit1.  
Micheal's fingerprint is in the unit 1 and unit2.  
Lizzy's fingerprint is in the unit2.

#### 4.3.6 Copy Privilege

Copy privilege is to copy employees' T&A method and access permission.

Choose employee info who need to set T&A method and access permission in employee info list (you can choose some or one through [Shift] or [Ctrl] key), click [Copy privilege] to open [Copy privilege] window as following,

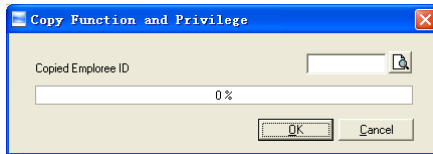

Pic4.4 Copy Privilege

Inputs the employee ID who will be copied and click [OK], system will pop-up confirm info:

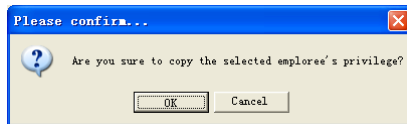

Click [OK] button and it will start coping privilege; Click [Cancel] button to exit.

#### 4.3.7 Download FP

Download FP is to download employees' FP stored in attendance terminal to PC which will not download employee info. Please make sure employee info has existed before downloading FP.

Choose employee info who needs to download FP in employee info list (you can choose some or one through [Shift] or [Ctrl] key), click [download FP] and system will prompt if the operation will continue or not, as following:

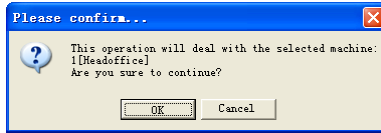

Click [OK] button and start download the employees' FP info from terminal.

Click [Cancel] to exit.

Downloading process is as following:

#### 4.3.8 Upload Employee & FP

Upload employee & FP is to upload employee info stored in PC to terminal.

Choose employee info who needs to upload FP in employee info list (you can choose some or one through [Shift] or [Ctrl] key), click [download FP] and system will prompt if the operation will continue or not, as following:

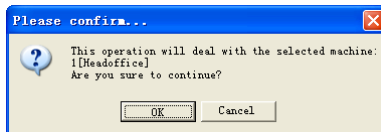

Click [OK] button to upload employees' info and FP from PC; Click [Cancel] button to exit.

Uploading process is as following:

Notice: The function of 'upload employee & FP' is the same as 'resume employee' which both store employee info to terminal. The difference is upload employee & FP enable user choose employees who need to be uploaded, but 'resume employee' is to upload all the employees stored in database to terminals.

#### 4.3.9 Delete employee from Unit

'Delete employee from unit' is meaning delete employee info from unit through software. Choose employee info need be deleted in employee info list (you can choose some or one through [Shift] or [Ctrl] key), click [delete employee from unit] and system will prompt as following:

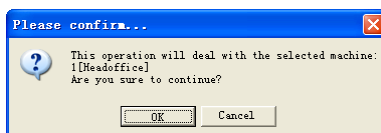

Click [OK] button to confirm and start delete the employee info; Click [Cancel] button to cancel this operation.

The main interface shows like following:

#### 4.3.10 Check Staff

Input the info of the employee like ID, name, unit location which are no necessary to fill up. Click [Check staff] button and correct employee info will show in the list

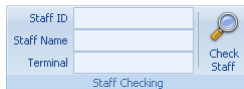

Click [Check staff] button, the results are corresponding staff info:

Staffer No.	Card No.	Name	Sex	Position	Birthday	Employ Date	Phone	/	Address	1st FP	Unit
8										<input checked="" type="checkbox"/>	1
5										<input checked="" type="checkbox"/>	1
4										<input checked="" type="checkbox"/>	1
3	772821									<input checked="" type="checkbox"/>	1
1										<input checked="" type="checkbox"/>	1
11										<input checked="" type="checkbox"/>	1
8101	13839321	Holly	Female	Software	1983-02-	2006-11-03	021-54833433		Minhang Sh	<input type="checkbox"/>	1

#### 4.3.11 Department Management

Click right button of mouse upon department icon [  ], pop-up the menu:

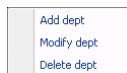

Add department

Choose Add dept. in the menu, which will pop-up the following window:

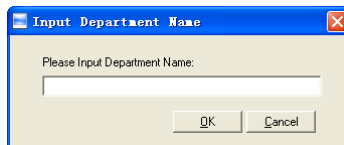

Input department name. Click [OK] button to save. Click [Cancel] to exit.

Modify department

Choose Edit dept. in the menu, which will pop-up the following window:

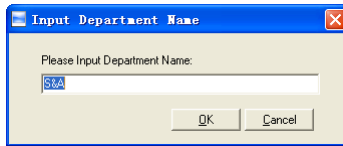

Input department name. Click [OK] button to save. Click [Cancel] to exit..

Delete department

Choose Delete dept. in the menu, which will pop-up the following window:

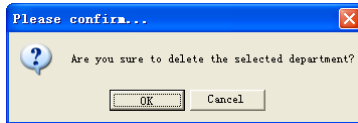

Input department name. Click [OK] button to save. Click [Cancel] to exit..

#### 4.3.12 Right-hand Button

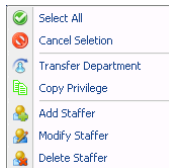

Select All: Select all records that are in the record list.

Cancel Selection: Cancel select the record.

Click options one by one in the menu and the following modules will pop up respectively: [Transfer Department], [Copy Privilege], [Add Employee], [Modify Employee] and [Delete Employee].

#### 4.4 Record Management

It is mainly to search, export records. It can use for backup record:



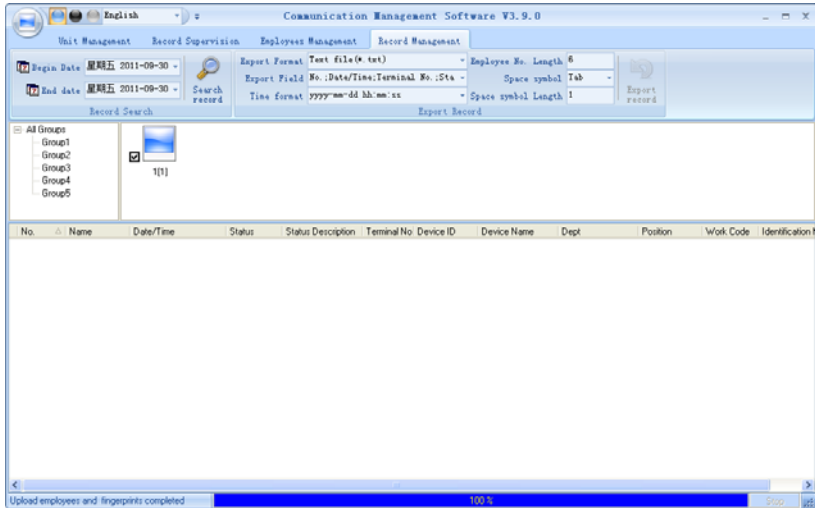

#### 4.4.1 Search Record

Search record is to search the downloaded attendance records in the time range.

Firstly set the date. Click the box after [Begin date] and [End date], there will pop-up calendar info as following:

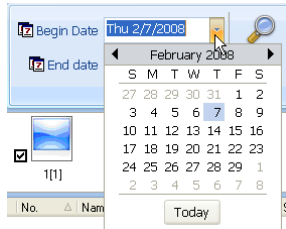

Click [ ◀ February 2008 ▶ ] choose the month or year needed to be set.

Then click [Search Record] button, the record of mach condition will show in record list:

No.	Name	Date/Time	Unit No.	Unit S/N	Unit Name	Dept	Position
1		2008-12-17 11:53:23	1	1	Head Office	Administrator Department	
1		2008-12-17 14:56:43	1	1	Head Office	Administrator Department	
1		2008-12-17 14:55:18	1	1	Head Office	Administrator Department	
10		2008-12-17 11:52:55	1	1	Head Office	Administrator Department	
10		2008-12-17 11:55:42	1	1	Head Office	Administrator Department	
10		2008-12-17 14:55:47	1	1	Head Office	Administrator Department	
11		2008-12-17 14:55:49	1	1	Head Office	Administrator Department	
12		2008-12-17 14:55:52	1	1	Head Office	Administrator Department	
2		2008-12-17 11:55:57	1	1	Head Office	Administrator Department	
2		2008-12-17 11:53:24	1	1	Head Office	Administrator Department	
2		2008-12-17 14:56:56	1	1	Head Office	Administrator Department	
2		2008-12-17 14:55:58	1	1	Head Office	Administrator Department	
3		2008-12-17 11:53:27	1	1	Head Office	Administrator Department	
3		2008-12-17 14:55:26	1	1	Head Office	Administrator Department	

#### 4.4.2 Export record

Export record is to backup the data stored in the database of PC to other space, so that if the current database is abnormal, it can be used to resume data:

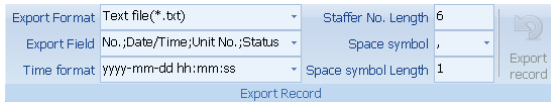

Export format: It has 3 formats optional: text file (.txt), CSV file (.csv), Excel files (.xls).

Export field: users can choose important fields or all to export.

Time format: 4 formats optional.

yyyy-mm-dd hh:mm:ss                      yyyy-m-d hh:mm:ss

yy-mm-dd hh:mm:ss                        yyyymmddhhmmss

Employee No. length: set employee No. length, the length of txt file is 4 digits, and the length of Excel file is 6digits.

Space symbol: space symbol to separate fields

Space symbol length: Space symbol bit

After setting completed, click [Export record] button, open 'Save as' window, choose save file directory, input file name as following:



Click [OK] button to confirm finishing export records.

#### 4.5 System Settings

Click  button, pop-up the following menu:

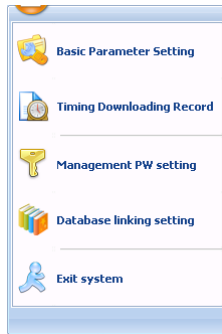

#### 4.5.1 Basic parameter setting★

Click [Basic parameter setting] item, pop-up [Basic parameter setting] window as following:

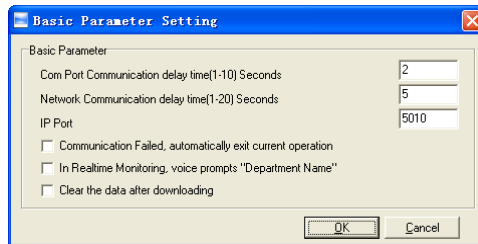

Com port Communication delay time (1-5) sec.: The default time is 3s.

Network Communication delay time (1-20) sec.: The default time is 5s.

Communication failed, automatically exit current operation: If timeout is larger than 'Communication delay time', software will automatically exit.

In Real-time Monitoring, voice prompts "Department name": During real-time monitor, if employee is access granted, the software will voice prompt employee department and name.

Clear the data after downloading: After downloading records completed, delete the record downloaded from machine automatically.

Choose parameter bases on practical situation, click [OK] button to save the setting of parameter; Click [Cancel] button to cancel the setting.

#### 4.5.2 T&A Status setting

Click the [T&A Status setting] option, and the [T&A status setting] window pops up:

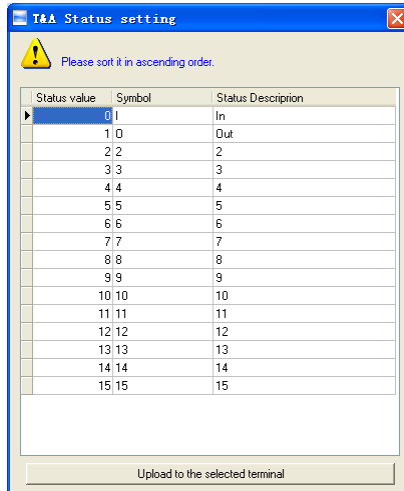

Click the state which is going to be modified. Input the status description.

[Upload to the selected terminal]: Upload the T&A status from the selected terminal.

#### 4.5.3 Timing downloading record

Click the [Timing Downloading Record]. The [Timing Downloading Record] window pops up:

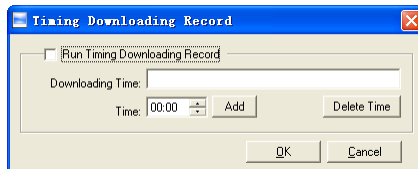

Enable this function by choosing the [Run Timing Download Record]. You can set 5 time point.

Please use the button [↑↓] to set a time. And then click the button [Add] to add the time to the [Downloading Time].

Click the button [OK] to save the setting.

#### 4.5.4 Management PW setting

Click [Management PW setting] item, open [Modify management password] window as following,

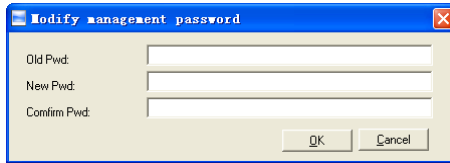

Old password: default password is empty. If user has modified password, please input this password which is used to log on system. If it's wrong, system will prompt,



Click [OK] and input old password again.

New Pwd: the password user wants to set

Confirm Pwd: input new password again to confirm. If confirm Pwd is different from new one, system will prompt:

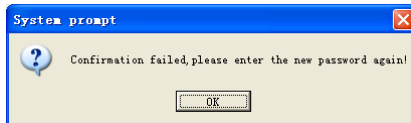

Click [OK] button to input confirm password again.

After modifying completed, click [OK] button to save new password and system will prompt:



Click [Cancel] button to exit.

#### 4.5.5 Database linking setting

Click [Database linking setting] item, pop-up [Data link properties] window as following:

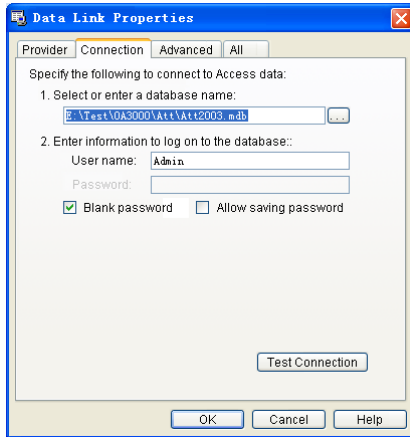

Click [...] button beside [1. Select or enter a database name:] to choose the linking database directory.

Choose database name, click [Open] button to confirm database linking and exit to [Data link properties] interface. If database set ID and password, input ID and password in [2]. Enter information to log on to the database]. After completed, click [Test connection] to test the connection correctness of the database and system prompts:

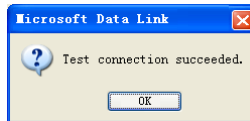

Click [OK] button to [Data link properties] interface. Click [OK] button and system prompts:

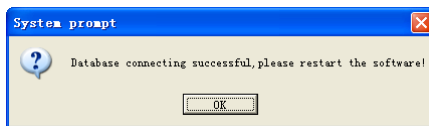

Click [OK] button to exit.

#### 4.5.6 Exit system

Click [Exit system] item, pop-up confirm info:

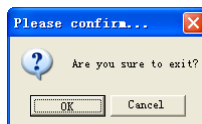

Click [OK] button to exit management software system. Click [Cancel] button to cancel this operation.

#### 4.6 Software Interface Setting

##### 4.6.1 Interface Skin Color

Choose [  ] button in title menu which enable change software interface color. The style is Windows XP system style.

##### 4.6.2 Language

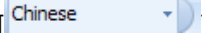
Choose [  ] button in title menu which enable convert between English and Chinese interface.

##### 4.6.3 Setting Quick Access Button

Add more functions to the titled language toolbar in order to quick access. For example: [Synchronize Time].

Click right button on [Synchronize Time], pop-up the following window:



Click [Add to quick access toolbar] and it will display in titled language toolbar:



Delete quick access button: When you need to delete the quick access button, click on the button, pop-up the menu. Click it and the quick access button will disappear:



Click the menu and we can delete the quick access button.

The Setting of other button is same as [Synchronize Time].

## Chapter 5

# Background Management

The main theme of this chapter is how to collect attendance records from different terminals with management software and generate different reports. The background software can manage employee information, set rules of attendance etc.

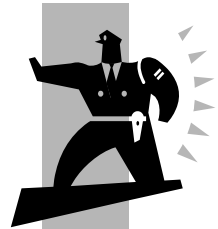



## 5 Background Management

Management software can collect attendance records from different terminals, calculate according to shift setting and finally generate different reports.

### 5.1 Login System

Double click the icon [  ] on the desktop to start the attendance background management program. The log-in interface will pop up as follows:

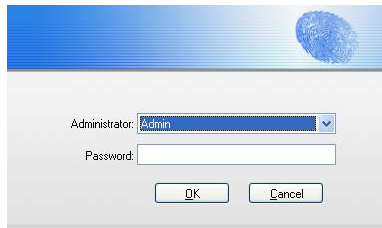

The default administrator's name is "Admin" and password is empty. Log in system and the following interface will be displayed:

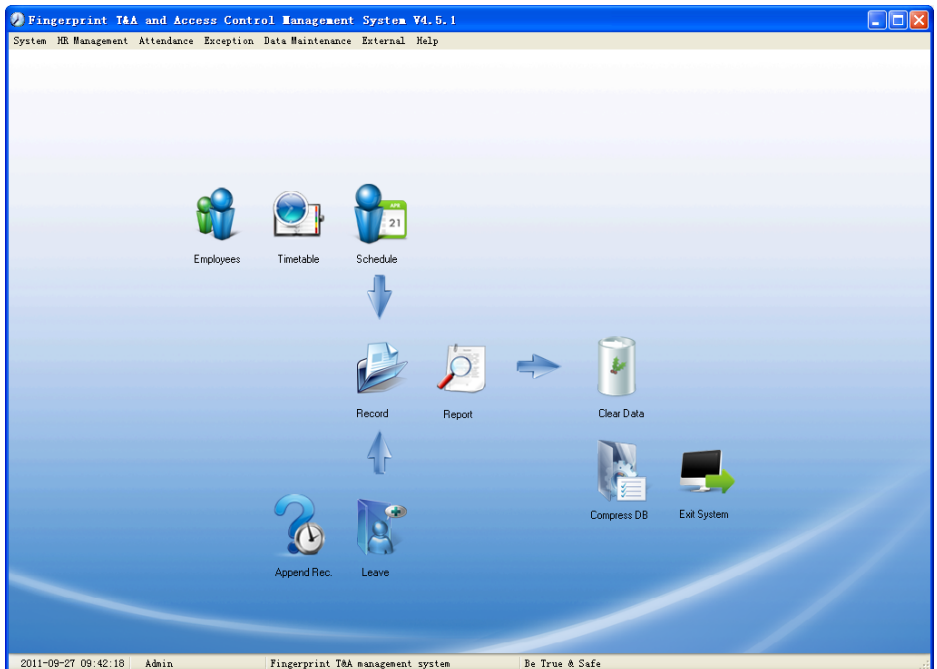

The main interface includes three parts:

1. System menu: Include the whole function module & information
2. Shortcut button: Shortcut button of common Set function module, array in working order, easy to work on
3. Status column: Show the current time, logged-in administrator and system information.

## 5.2 System

Click [**System**] on the main menu, following springs:

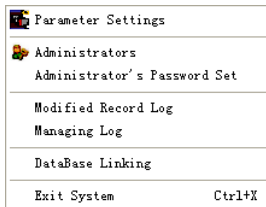

### 5.2.1 Parameters Settings

Click [**Parameters Settings**] in system menu. The following window will prompt:

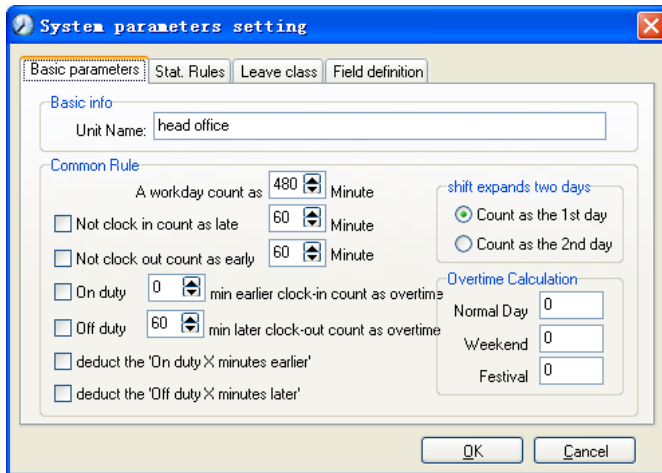

Basic parameters:

Set your company name, the default is “Head office”

Input your company name that will be deemed as the head of departments list.

A working day count as how many minutes is the base for time attendance calculation which will be the transition standard to calculate the late to work/early to

leave /free overtime items, minute is the good transition standard of hours and working day.

“Late for work as how many minutes” can be set when no clock-in on duty, “early to leave as how many minutes” when no clock out for off duty. Free overtime work can also be calculated on the base that how many minutes working after off duty time.

“Shift expand two days” is set under real condition.

Overtime Calculation: Different multiples for calculate overtime.

Stat. Rules:

Click page [Stat. Rules] in pic5.1, following shows:

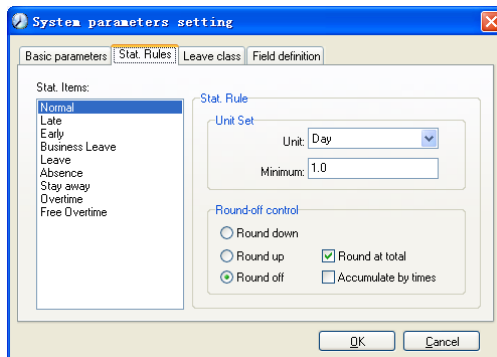

This page describes the stat. rules of items: normal, late, early, business leave, leave, absence, overtime, free overtime.

Accumulate by times: Only calculate the total times, display the accumulated times in report.

Round at total: Add up the total time and then round according to corresponding unit.

Round down: Abandon the decimal regardless it is. For example, if the minimum calculation unit is 1 day, if the accumulated time is 1.1 days or 1.9 days, the result of calculation is 1 day.

Round up: Add one unit regardless the decimal is. For example, if the minimum calculation unit is 1 day, if the accumulated time is 1.1 days or 1.9 days, the result of calculation is 2 day.

Round off: If the decimal is equal to or over 0.5, add one unit, or else, abandon

it.

Notice: the setting of stat. Rules above will directly affect the statistical result

Please make above setting according to the true status of your company to ensure the accuracy of reports.

Leave class:

Click page [Leave class] in pic5.1, following shows:

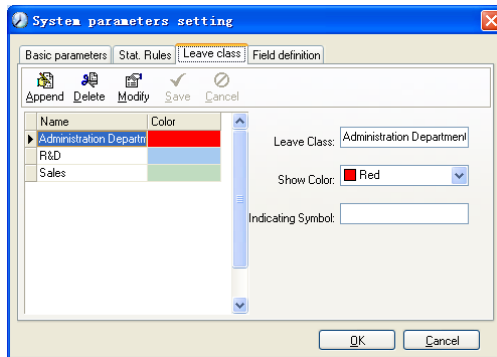

Add new leave class:

Click [Append], input the name of leave class and choose color and click [save] to finish.

Revise leave class:

Select the name of leave class which one need to be revised, click [Modify], input new name of leave class and color, and click [Save] to finish.

Delete leave class:

Select the name of leave class which one need to be deleted, click [Delete], and click [OK] to finish.

Field definition:

Click page [Field definition] in pic5.1, following shows:

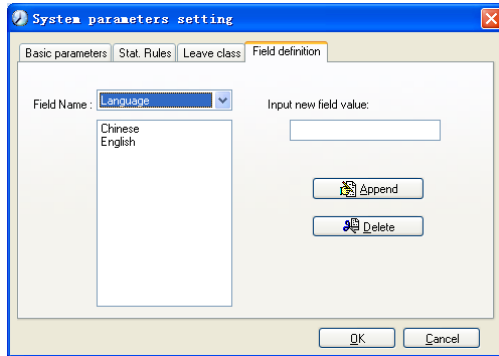

This page add the corresponding value for [Nation], [Specialty], [Position] [Education] in menu [Employee maintenance].

### 5.2.2 Administrators

Click [System]-[Administrators], following window shows:

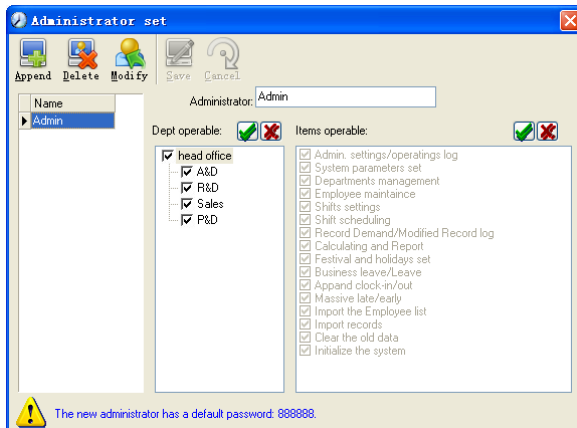

Append new administrator:

Click [Append]—input the name of new administrator within input field.

Of [Administrators], select corresponding privileges below and click [Save] to finish adding of new administrator. The default password of new administrator is 888888. Please log in as the new registered administrator and click menu [System] -- [Administrator's password set] to set new password of administrator for system security.

Note:

1. Before you using the administrator mode, you need to set the privileges for every administrator with which the administrator can modify the operation items after he log in the software; there are all the items in the “Items operable” list in above picture, such as “Employee maintenance, Shifts settings, Calculating and Report”; we can set different privileges for different administrators so as to divide and manage the task systematically.

2. After you add a new department, you must modify the privileges of the “Department operable” for the administrators (select the new department in the “Department operable” list and save), who will have the privileges to modify the new department, and then you may do other operations.

Modify administrator:

Select the name of administrator, click [Modify], input new name of administrator and corresponding rights in [Administrator] and click [Save] to finish.

Delete administrator:

Select the name of administrator who will be deleted and click [Delete] to finish deleting according to the prompt.

### 5.2.3 Administrator's Password Set

Click menu [System]--[Administrator's Password Set], following springs:

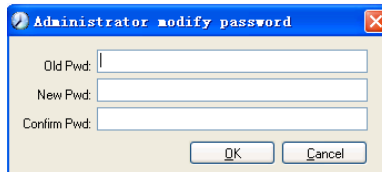
A screenshot of a Windows-style dialog box titled "Administrator modify password". The dialog has a blue title bar with a close button (X) in the top right corner. The main area is light beige and contains three text input fields stacked vertically. The first field is labeled "Old Pwd:", the second "New Pwd:", and the third "Confirm Pwd:". At the bottom of the dialog, there are two buttons: "OK" and "Cancel".

Input the original password in [Old Pwd], enter the new password in [New Pwd], enter again in [Confirm Pwd] and click [OK] to finish.

### 5.2.4 Modified Record Log

Click menu [System]--[Modified Record Log], following springs:

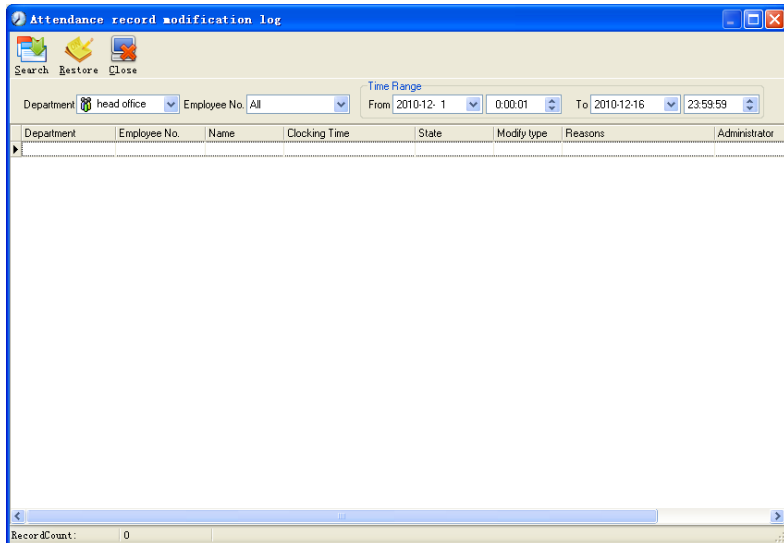

Select department, employee No. and time range and click [Search] and those records which match the above condition will be displayed.

Notice: Modified record log shows all the time attendance record modifications; If there's record that has been revised incorrectly before, it can be recovered by selecting this record and clicking [Restore].

Click [Close] to exit.

### 5.2.5 Managing Log

Click menu [System]--[Managing Log], following springs:

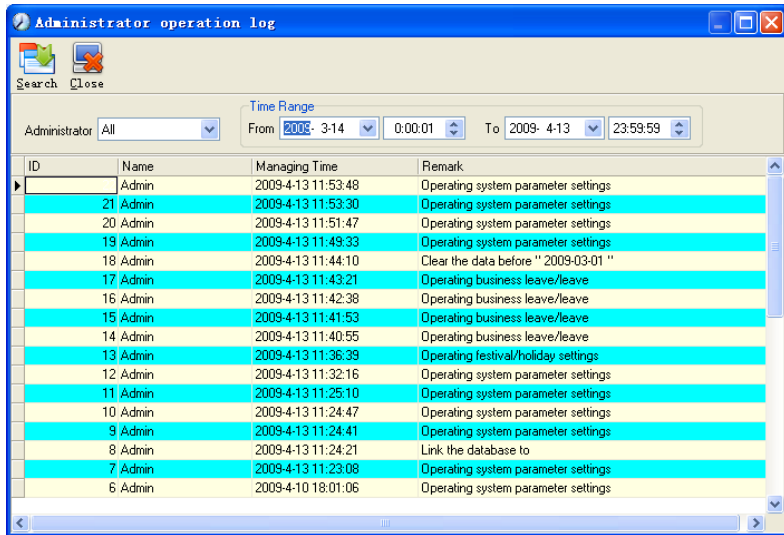

This log records all the operations of every administrator. Select [Administrator] and the time range then click [Search] to see what operations have been done by this administrator within the selected time range, which makes it possible that the multi-administrators can use the software at the same time.

### 5.2.6 Set Database Link

This system adopts the database interface of Microsoft ADO. The acquiescence database is Access2000. The defaulted is att2003.mdb under the main setup directory. You can set up the database linking again according to the actual conditions.

When the following mistake appears, you should link database again:

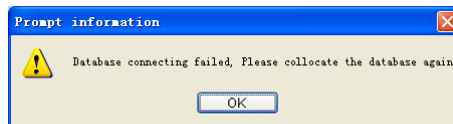

Click [Database linking] in system menu, the following springs.



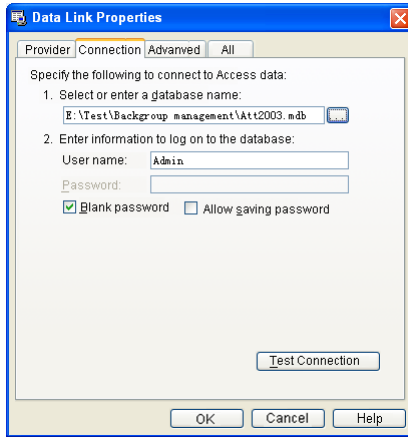

Input the database name or click the  button to select the correct database file.

Notice: You can click [Test connection] to test the connection correctness of the database.

### 5.2.7 Exit System

Click [Exit System] in System menu. The following menu springs:

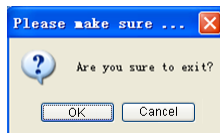

Click [OK] to exit management software and return to Windows system.

## 5.3 HR Management

Click [HR Management] on the main menu, following springs:

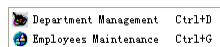

### 5.3.1 Department Management

Click [Department Management] in the [HR Management] menu, springs the following window:

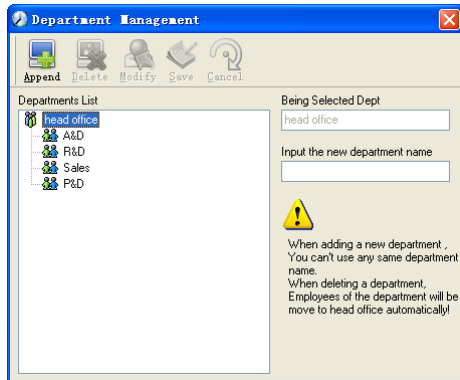

Add a new department:

Click [Append], input the new department name and click [Save] to add a sub department for the chosen department.

Note: when you want to do some other operations to the new department, you need to set the privilege of modifying the new department for the administrator in the [administrator set] first (choose the new department you just added in the "Department operable").

Department modification:

Choose the department, click [Modify] and input the new department name, then click [Save].

Delete the department:

Choose the department, click [Delete] and then click [OK] to complete.

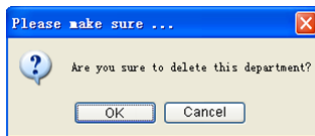

Notice: repetition of department name is not allowed; if there are employees existing in the deleted department, those employees will be automatically transferred to department of head office.

### 5.3.2 Employees Maintenance

Click [Employees Maintenance] in [HR Management] menu, the following window appears:

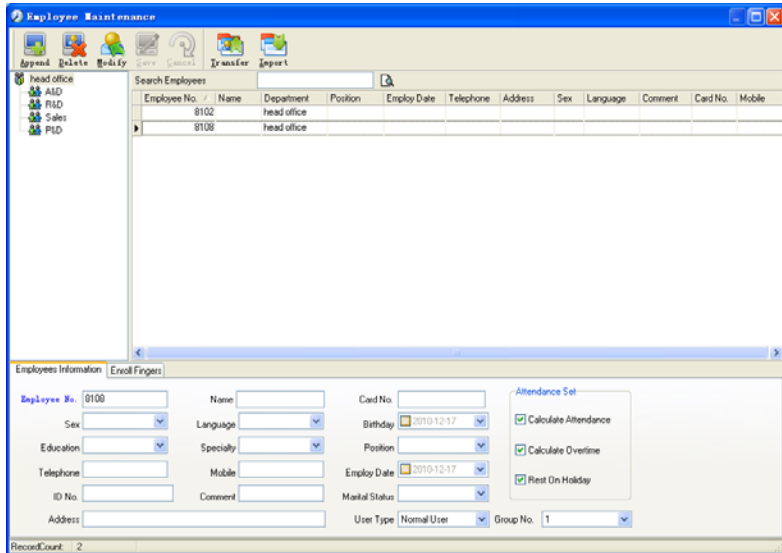

### Employee's adding:

Choose the department that the employees belong to, clicks [Append], and input employee's information, then click [Save] to complete.

Note: 1. The items of "Calculate attendance", "Calculate overtime", "Rest on holiday" below "Attendance Set" is correlated with report, please set it correctly. If the checkbox of "Calculate Attendance" of this employee is not checked, there will be no statistical result for this employee in the report. If checkbox "Calculate Overtime" is not checked, the statistical result of overtime of this employee will be 0, unless he had [Temporary Shifts] which defines as overtime working; If the checkbox of "Rest On Holiday" is not checked, holidays will make no effect on the shifts for this employee; if the checkbox of "Rest On Holiday" is checked, thus for those holidays, even there are shifts on those days for the employee, those shifts will be invalid. And if there are time attendance records of this employee, those records will be deemed as free overtime.

2. Employee No. is exclusive as well as the first digit cannot be 0!

### Employee's modification:

Choose the employee, click [Modify] and input the new information, then click [Save].

Employee's deletion:

Choose the employee; click [Delete] and then click [OK] to complete.

Please be cautious when delete the employee since all this employee's time attendance records, shift arrangement will be deleted at the same time.

Import employees:

Click [Import], employee importation window springs for importing employees.

Employee's department shifting:

Choose the employee you want to shift the department click [Transfer] and following window will pop up:

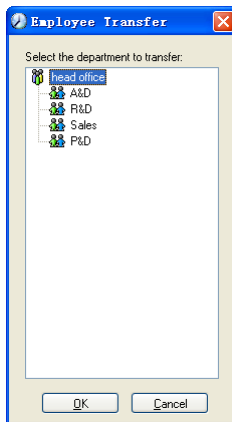

Select the new department and click [OK] to complete.

Export Employee:

Right-click on employee list and the following window pops:

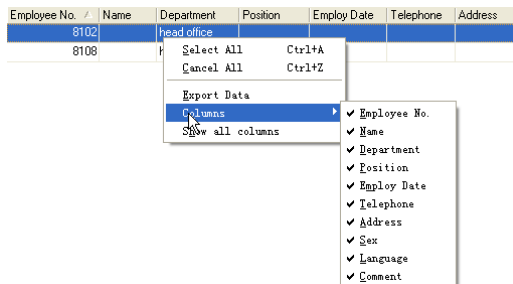

All displayed fields in employee info list can be defined through submenu of "Column". Meanwhile, the modification will take effect and be saved.

Click [Show all columns] to display all fields in the list.

Click [Export Data] and following window will prompt:

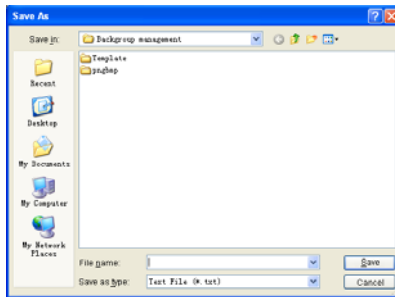

Please select your target directory of your export, file format (txt or xls) and the file name. Click [Save] to confirm the operation.

Notice: Exported Excel file can be used as backup information and can be imported again.

#### 5.4 Attendance Management

Click [**Attendance**] in the main menu, following springs:

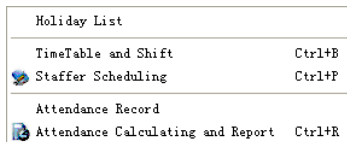

##### 5.4.1 Holiday List

Click [Holiday List] in [Attendance] menu. The following appears.

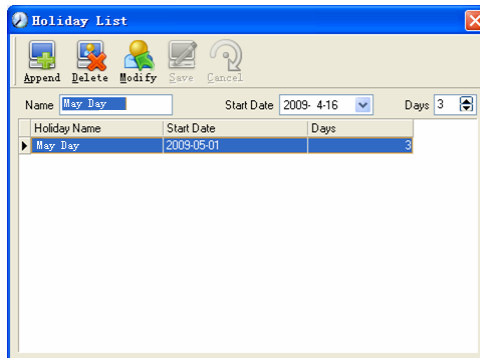

Add festivals or holidays:

Click [Append] then input the festival or holiday name and the rules. Click [Save] when ready.

Modification of festivals or holidays:

Select the festivals or holidays you want to revise, then click [Modify] and input the new information. Click [Save] when ready.

Deletion of festivals or holidays:

Select the festivals or holidays you want to delete, and then click [Delete] to perform Deletion of festivals or holidays.

#### 5.4.2 Timetable and Shift

The relationship between shift and timetables:

Shift setup should be done in two steps: First, setup necessary timetables. Second, setup shifts. One or more timetables can be included in one shift.

Timetable is the time period between On-duty and Off-duty required in the company rule. For instance, the company rule requires the working hours be 08:00-12:00 and 13:00-17:00; so 08:00-12:00 and 13:00-17:00 are two timetables. If such a shift needs to be setup, these two timetables should be setup first. Here, we use time table “morning” to indicate “08:00-12:00” and time table “afternoon” to indicate “13:00-17:00”; so two timetables have been setup. (Please refer to the following chapter for details of how to add time tables) and then we can add a shift such as “Normal shift” in which “shift cycle” and “cycle unit” will be setup. Then we should add two timetables - “morning” and “afternoon” so that a shift setup is completed. Brief introduction is mentioned here for you to get a general picture of the relationship between timetable and shift. The details of shift setup will be found in the next two sections.

Timetable maintenance:

Click [Timetable and Shift] in [Attendance] menu. The following window appears.

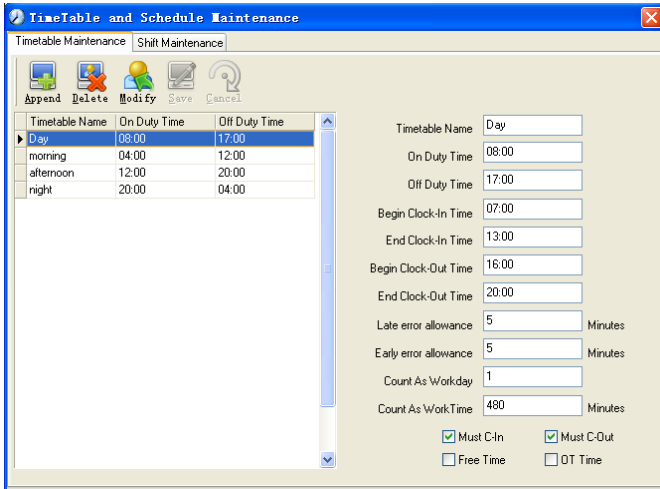

Pic5.2

Add a new timetable:

Click [Append] and enter the corresponding information:

[Timetable Name] For instance: Day Shift

[On duty Time] (08:00)

[Off duty Time] (17:00)

[Begin Clock-in Time] (07:00)

[End Clock-in Time] (13:00)

[Begin Clock-out Time] (16:00)

[End Clock-out Time] (20:00),

[Late error allowance] (5)

[Early error allowance] (5)

[Count as work day] (1)

[Count as work time XXX minutes] (480).

Tick [Must C-In] and [Must C-out],

Finally click [Save] to confirm.

(Please note: Every item should be setup in timetables with no blank left. [Begin Clock-in Time] and [End Clock-in Time] setup the valid time period for clock-in. Records out of this time range will be treated as invalid ones. For instance [Begin Clock-in Time] is 07:00 and [End Clock-in Time] is 13:00. If clock-in record is 07:01 or 12:59, they are valid records but if clock-in record is 06:59, it is invalid. Besides, [Begin Clock-in Time] and [End Clock-in Time] can be more than one day (meaning [End Clock-in Time] can be before [Begin Clock-in Time]) but it can't be longer than 24 hours.

[Late error allowance] means how many minutes after [On duty] are treated as “late”, [Early error allowance] means how many minutes before [End Clock-in Time] are treated as “early”; [Count as work day] and [Count as work time XXX minutes] are used in calculating business leave, leave, absence and overtime.

Checking [Must C-In] and [Must C-out] or not will affect the result of calculation. If [Must C-In] is checked and the timetable is included of Employee A's shift, he will be either considered absence or treated according to [Not clock in count as late XXX minutes] in [Parameter Settings] If he didn't clock in or ask for leave. Otherwise, even if there is off duty record for him only, his attendance will be treated as normal.

#### The timetable Modification

Select the timetable name you want to revise, and click [Modify], then input the new information, clicks [Save] when finished.

#### The timetable Deletion

Select the timetable you want to delete, click [Delete], and click [OK] to make sure.

(Please note: Begin Clock-in Time and End Clock-in Time makes the valid time range for Clock in. Clock in out of this time range will be treated as invalid records. It is the same with Clock-out time. Please setup in accordance with practical situations.)

Example——Add a timetable:

Complete process for adding four timetables:

Day shift 08:00 - 17:00      Morning shift 04:00 - 12:00

Noon shift 12:00 - 20:00      Night shift 20:00 - 04:00

(Other information can be setup according to practical situations. Please refer to Pic5.2. Please note there should be no blank left.)

#### Shift Maintenance

Click [Shift Maintenance] in Pic5.2 and the following window pops up:



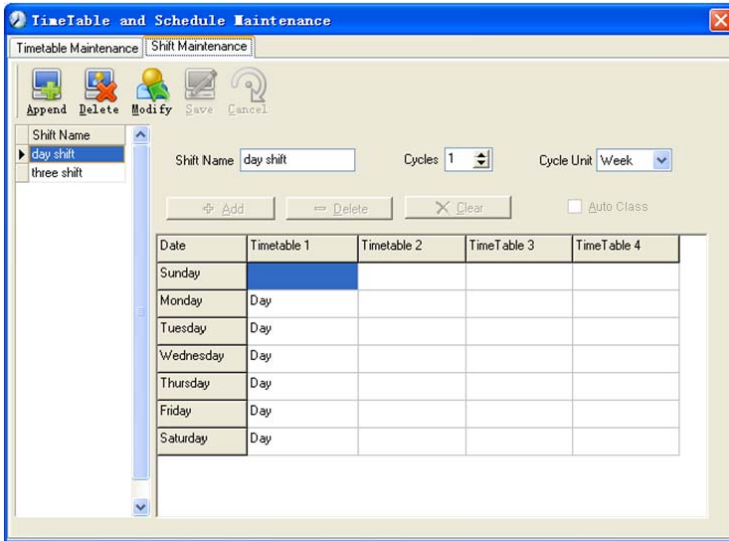

Add a shift:

Click [Append] and enter corresponding shift information in [Shift Name] such as: normal shift [Cycle] (1), [Cycle Unit] (week), and click [Add], select the timetables and time range required in this shift in the springing window (see the Pic5.3 below) For instance, select the timetable – Day shift and select from Monday to Friday and then click [OK], back to this window and click [Save] to complete. (Please refer to the example for details.).

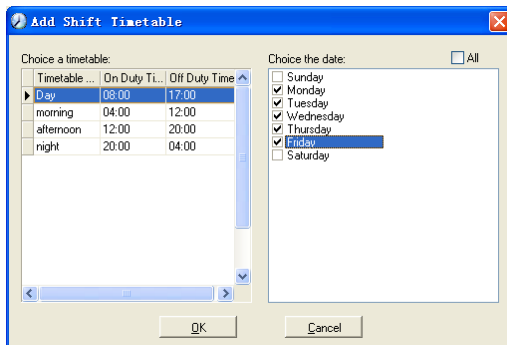

Pic5.3

Delete the timetable: Select the timetable you want to delete and click [Delete].

Clear the timetable: Clear all the timetables of the shift.

Arrange the shift automatically: when an employee has several shifts during one period, he need to finish all the shifts if it is not arranged the shifts automatically otherwise he will be regarded as absence; if you select the [Arrange the shift automatically], just finishing one shift of the period is reared as normal attendance.

Modify a shift:

Select the shift to be modified and click [Modify], and enter new information in [Shift Name] etc., click [Save] to complete.

Delete a shift:

Select the shift to be deleted and click [Delete].

Example---Three shifts:

Add “Three shifts” Shift (Please note: It is assumed that the shift goes around every week, cycle every three weeks and employee is on holiday every Saturday and Sunday.)

Step 1:

Click [Append], enter “Three shifts” in [Shift Name], set [Cycle] to “3” and [Cycle Unit] to “Week”. Please see the picture below:

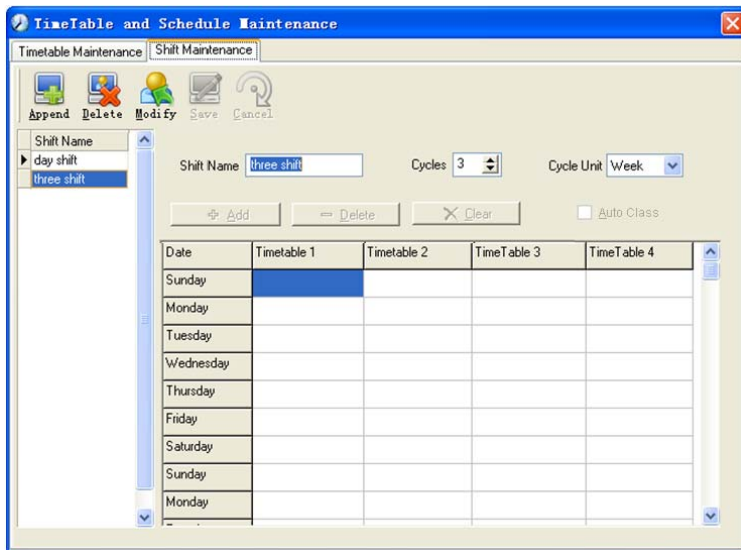

Step2

Add corresponding working hour timetable in accordance with “Cycle”: first week (morning shift, from Monday to Friday)

Click [Add] and the following window pops up:

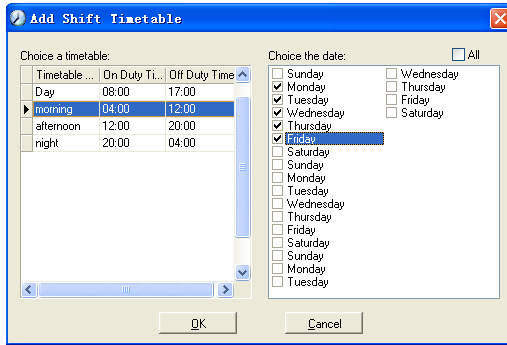

Select the timetable “Morning shift” to be added and select the time range to apply to this timetable “from Monday to Friday of the first week” and click [OK] to complete the setting of the first week.

The second week (afternoon shift, from Monday to Friday)

Click [Add]; make corresponding operation in the springing window (see the result below):

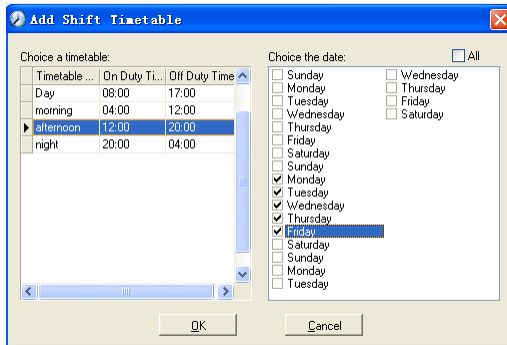

Click [OK] to complete the working hour setting for the second week.

The third week (night shift, from Monday to Friday)

Click [Add]; make corresponding operation in the springing window (see the result below):

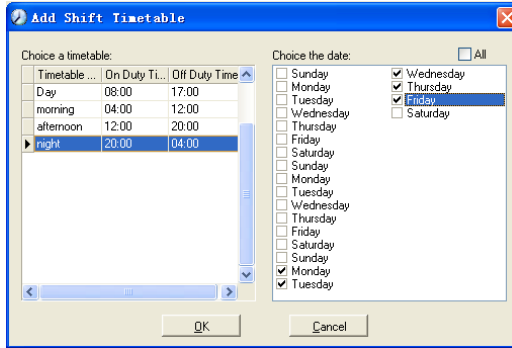

Click [OK] to complete the working hour setting for the third week.

After the completion of above steps, please don't forget to click [Save] and the setup of "three shifts" will be done (see the picture below):

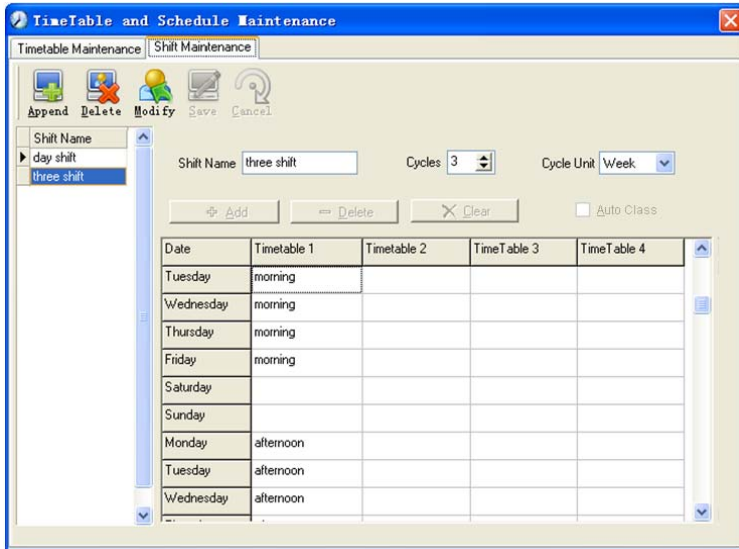

### 5.4.3 Employee Scheduling

Click [Employee Scheduling] in [Attendance] menu. The following window appears:

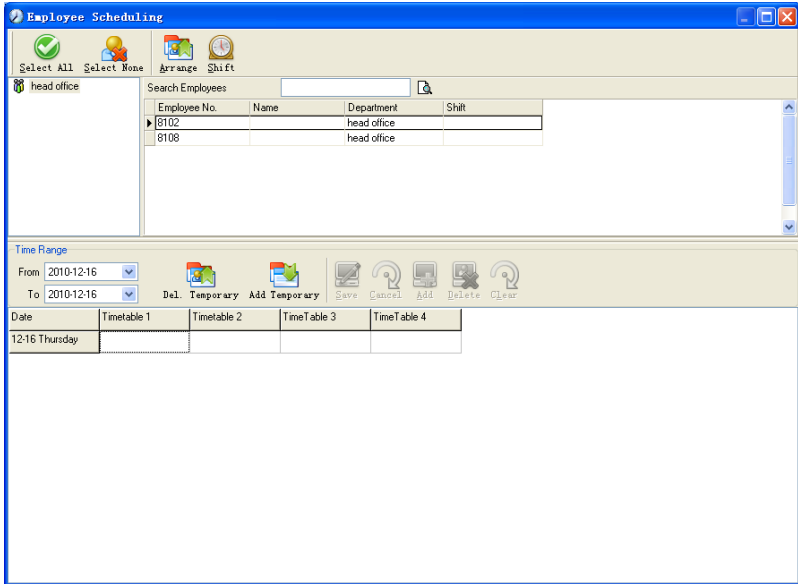

Pic5.4

Choose the department or several personnel that need to arrange shifts, click [Arrange], the following window appears:

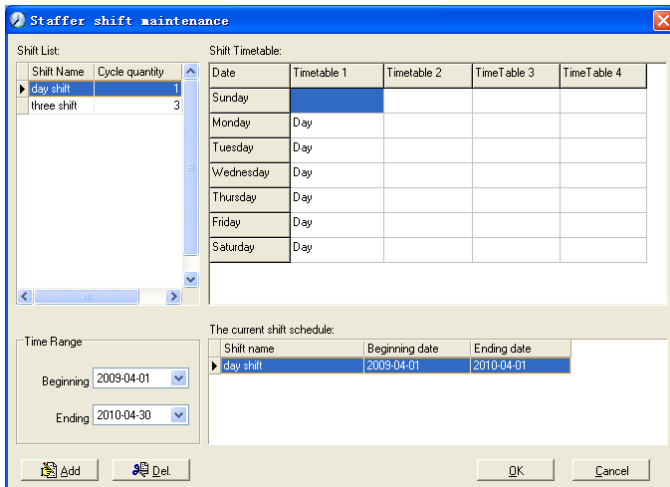

Pic5.5

Add a new shift:

Select the corresponding shifts, for instance: The commencement date and deadline of this shift of "normal class ", click [Add] button and then click [OK] in Pic5.5 to finish the adding of new shifts.

Please note:

If the cycle unit of scheduling is "week" and the amount of cycle is more than 2, the starting date should setup as "Sunday".

If the cycle unit of scheduling is "month" and the amount of cycle is more than 2, the starting date should setup as "1st day of a month".

Deletion of the shifts:

Select the shifts in the shifts form which you want to delete, click Delete button, and click ok on the pop up dialog box to finish the deletion.

Arrange a Temporary Shift:

When one or many employee's working time needs to be changed temporarily, you can arrange a temporary shift. Click [Add Temporary] the following window appears:

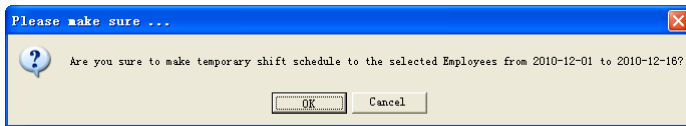

Click [OK] and the temporary scheduling can be operated. Then click [Add] and the following window will pop up:

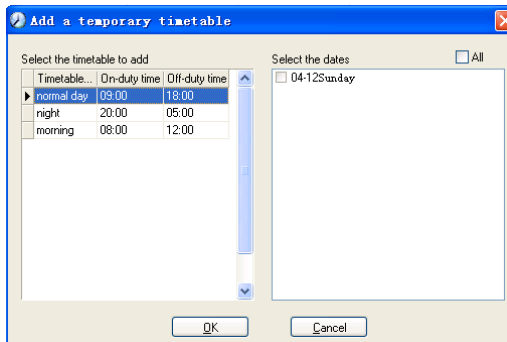

Click [OK] and the timetables will be saved. Click [Save] and the temporary scheduling will be saved.

[Delete]: Delete the selected timetable;

[Clear]: Delete all the timetables in the current time range;

[Cancel]: Delete the existing temporary scheduling in the selected time range;

#### 5.4.4 Attendance Records

Click [Attendance Records] in [Attendance] menu, the following appears:

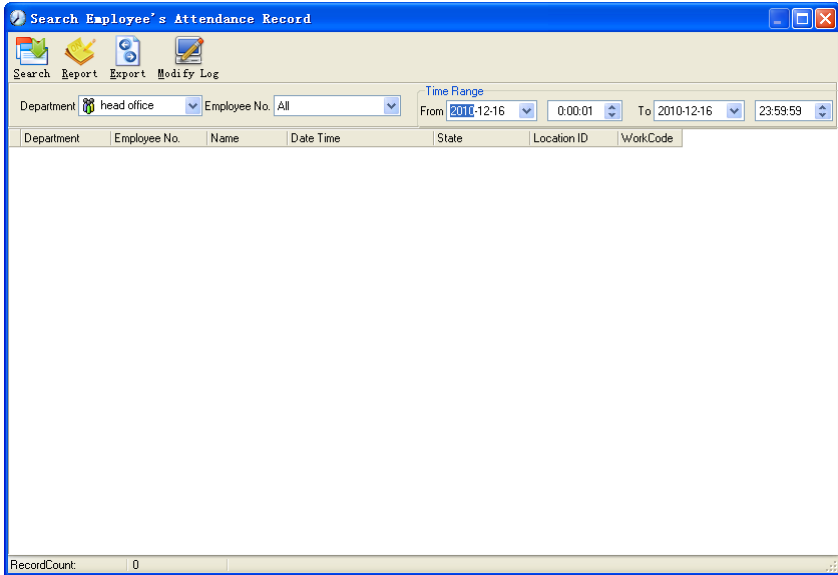

Inquiry of attendance record:

Select the department, employee, the beginning and ending time that need to inquire about, then click search, you can get the corresponding attendance record.

**Search Employee's Attendance Record**

Search Report Export Modify Log

Department: head office Employee No.: All Time Range: From 2010-12-1 0:00:01 To 2010-12-16 23:59:59

Department	Employee No.	Name	Date Time	State	Location ID	WorkCode
head office	8103	Micheal	2010-12-03 08:53:00			0
head office	8103	Micheal	2010-12-06 08:53:00			0
head office	8103	Micheal	2010-12-06 18:03:36			0
head office	8103	Micheal	2010-12-07 08:53:00			0
head office	8103	Micheal	2010-12-07 18:03:36			0
head office	8103	Micheal	2010-12-08 08:53:00			0
head office	8103	Micheal	2010-12-08 18:03:36			0
head office	8103	Micheal	2010-12-09 08:53:00			0
head office	8103	Micheal	2010-12-09 18:03:36			0
head office	8103	Micheal	2010-12-10 08:53:00			0
head office	8103	Micheal	2010-12-10 18:03:36			0
head office	8103	Micheal	2010-12-13 08:53:00			0
head office	8103	Micheal	2010-12-13 18:03:36			0
head office	8103	Micheal	2010-12-14 08:53:00			0
head office	8103	Micheal	2010-12-14 18:01:35			0
head office	8103	Micheal	2010-12-15 08:53:00			0
head office	8103	Micheal	2010-12-15 18:05:52			0
head office	8103	Micheal	2010-12-16 08:53:00			0
head office	8103	Micheal	2010-12-16 17:59:52			0
head office	8108	Lizzy	2010-12-01 08:56:00			0
head office	8108	Lizzy	2010-12-01 18:12:00			0
head office	8108	Lizzy	2010-12-02 08:56:00			0
head office	8108	Lizzy	2010-12-02 18:12:00			0
head office	8108	Lizzy	2010-12-03 08:56:00			0

RecordCount: 75

Attendance record report form preview:

Click [Report] when the window displays the attendance inquiry records, you can get the report form automatically.



Preview

100%

### Head office attendance record report

2009-04-01 To 2009-04-16

Department			King Chen 8001			R&D			King Jin 8103			P&D			Mark Simth 8105		
			2009-4-1 7:23:05	Clock In		2009-4-1 7:23:05	Clock In		2009-4-1 7:23:05	Clock In		2009-4-1 7:23:05	Clock In		2009-4-1 7:23:05	Clock In	
			2009-4-1 17:00:59	Clock Out		2009-4-1 17:00:59	Clock Out		2009-4-1 17:00:59	Clock Out		2009-4-1 17:00:59	Clock Out		2009-4-1 17:00:59	Clock Out	
			2009-4-2 7:45:35	Clock In		2009-4-2 7:45:35	Clock In		2009-4-2 7:45:35	Clock In		2009-4-2 7:45:35	Clock In		2009-4-2 7:45:35	Clock In	
			2009-4-2 17:05:16	Clock Out		2009-4-2 17:05:16	Clock Out		2009-4-2 17:05:16	Clock Out		2009-4-2 17:05:16	Clock Out		2009-4-2 17:05:16	Clock Out	
			2009-4-3 7:52:12	Clock In		2009-4-3 7:52:12	Clock In		2009-4-3 7:52:12	Clock In		2009-4-3 7:52:12	Clock In		2009-4-3 7:52:12	Clock In	
			2009-4-3 17:01:54	Clock Out		2009-4-3 17:01:54	Clock Out		2009-4-3 17:01:54	Clock Out		2009-4-3 17:01:54	Clock Out		2009-4-3 17:01:54	Clock Out	
			2009-4-4 7:43:54	Clock In		2009-4-4 7:43:54	Clock In		2009-4-4 7:43:54	Clock In		2009-4-4 7:43:54	Clock In		2009-4-4 7:43:54	Clock In	
			2009-4-6 7:38:36	Clock In		2009-4-6 7:38:36	Clock In		2009-4-6 7:38:36	Clock In		2009-4-6 7:38:36	Clock In		2009-4-6 7:38:36	Clock In	
			2009-4-6 17:08:42	Clock Out		2009-4-6 17:08:42	Clock Out		2009-4-6 17:08:42	Clock Out		2009-4-6 17:08:42	Clock Out		2009-4-6 17:08:42	Clock Out	
			2009-4-7 7:45:16	Clock In		2009-4-7 7:45:16	Clock In		2009-4-7 7:45:16	Clock In		2009-4-7 7:45:16	Clock In		2009-4-7 7:45:16	Clock In	
			2009-4-7 17:14:20	Clock Out		2009-4-7 17:14:20	Clock Out		2009-4-7 17:14:20	Clock Out		2009-4-7 17:14:20	Clock Out		2009-4-7 17:14:20	Clock Out	
			2009-4-8 7:08:12	Clock In		2009-4-8 7:08:12	Clock In		2009-4-8 7:08:12	Clock In		2009-4-8 7:08:12	Clock In		2009-4-8 7:08:12	Clock In	
			2009-4-8 7:24:53	Clock In		2009-4-8 7:24:53	Clock In		2009-4-8 7:24:53	Clock In		2009-4-8 7:24:53	Clock In		2009-4-8 7:24:53	Clock In	
			2009-4-8 17:20:05	Clock Out		2009-4-8 17:20:05	Clock Out		2009-4-8 17:20:05	Clock Out		2009-4-8 17:20:05	Clock Out		2009-4-8 17:20:05	Clock Out	
			2009-4-9 7:49:52	Clock In		2009-4-9 7:49:52	Clock In		2009-4-9 7:49:52	Clock In		2009-4-9 7:49:52	Clock In		2009-4-9 7:49:52	Clock In	
			2009-4-9 7:51:56	Clock In		2009-4-9 7:51:56	Clock In		2009-4-9 7:51:56	Clock In		2009-4-9 7:51:56	Clock In		2009-4-9 7:51:56	Clock In	
			2009-4-9 8:02:15	Clock In		2009-4-9 8:02:15	Clock In		2009-4-9 8:02:15	Clock In		2009-4-9 8:02:15	Clock In		2009-4-9 8:02:15	Clock In	
			2009-4-9 17:11:24	Clock Out		2009-4-9 17:11:24	Clock Out		2009-4-9 17:11:24	Clock Out		2009-4-9 17:11:24	Clock Out		2009-4-9 17:11:24	Clock Out	
			2009-4-10 7:45:19	Clock In		2009-4-10 7:45:19	Clock In		2009-4-10 7:45:19	Clock In		2009-4-10 7:45:19	Clock In		2009-4-10 7:45:19	Clock In	
			2009-4-10 17:04:34	Clock Out		2009-4-10 17:04:34	Clock Out		2009-4-10 17:04:34	Clock Out		2009-4-10 17:04:34	Clock Out		2009-4-10 17:04:34	Clock Out	
			2009-4-13 7:35:46	Clock In		2009-4-13 7:35:46	Clock In		2009-4-13 7:35:46	Clock In		2009-4-13 7:35:46	Clock In		2009-4-13 7:35:46	Clock In	
			2009-4-13 17:27:06	Clock Out		2009-4-13 17:27:06	Clock Out		2009-4-13 17:27:06	Clock Out		2009-4-13 17:27:06	Clock Out		2009-4-13 17:27:06	Clock Out	
			2009-4-13 7:06:12	Clock In		2009-4-13 7:06:12	Clock In		2009-4-13 7:06:12	Clock In		2009-4-13 7:06:12	Clock In		2009-4-13 7:06:12	Clock In	
			2009-4-14 17:16:25	Clock Out		2009-4-14 17:16:25	Clock Out		2009-4-14 17:16:25	Clock Out		2009-4-14 17:16:25	Clock Out		2009-4-14 17:16:25	Clock Out	
			2009-4-15 7:46:59	Clock In		2009-4-15 7:46:59	Clock In		2009-4-15 7:46:59	Clock In		2009-4-15 7:46:59	Clock In		2009-4-15 7:46:59	Clock In	
			2009-4-15 17:08:53	Clock Out		2009-4-15 17:08:53	Clock Out		2009-4-15 17:08:53	Clock Out		2009-4-15 17:08:53	Clock Out		2009-4-15 17:08:53	Clock Out	
			Count: 27						Count: 27						Count: 27		

Page 1/1

## Attendance records exporting

If need to lead out the attendance record, only need to click export, you can lead out the data inquired. (File format: \*.txt, \*.xls)

Click [Modify Log] and the log-modifying window will be called for reviewing the modification log of time and attendance records.

### 5.4.5 Attendance Calculating and Report

Inquiry of report form:

Click [Attendance Calculating and Report] in [Attendance] menu, the following window appears:

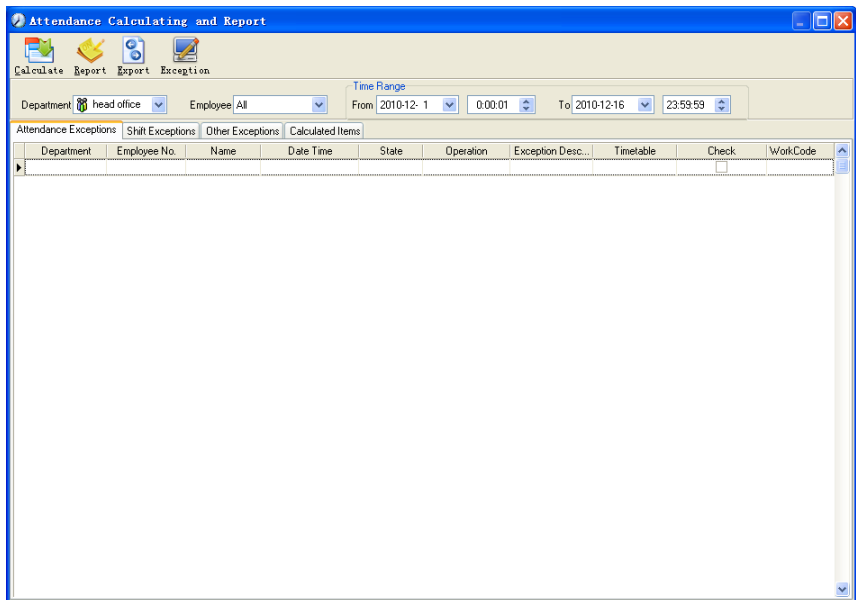

Pic5.6

Select the beginning, the ending date and the department and employee that need to be calculated and then click [Calculate].

There are four Tabs of information after search and calculation which can be viewed respectively:

[Attendance Exceptions]: Display the dealt result of the original attendance records;

[Shift Exceptions]: Display Employee's attendance result in the scheduled time period;

[Other Exceptions]: Display Employee's leaved, out and overtime etc.

[Calculated Items]: Display all Employee's calculated items such as "normal", "actual", "late", "early", "absent", "overtime" etc.

Please note: When dealing with "Out" calculation, there should be "Out back" and only "Out" and "Out back" in one shift can be calculated.

Working hours in the report="Actual" -"Late"-"Early"-"Out"

Exceptions of attendance records dealt with:

Open the attendance exceptions option card to deal with the records:

Attendance Calculating and Report

Calculate Report Export Exception

Department: head office Employee: All Time Range: From 2010-12-1 0:00:01 To 2010-12-16 23:59:59

Department	Employee No.	Name	Date Time	State	Operation	Exception Desc.	Timetable	Check	WorkCode
head office	8108		2010-12-01 08:56:00	Clock In		Normal record	Day	<input type="checkbox"/>	0
head office	8108		2010-12-01 18:12:00	Clock Out		Normal record	Day	<input type="checkbox"/>	0
head office	8108		2010-12-02 08:56:00	Clock In		Normal record	Day	<input type="checkbox"/>	0
head office	8108		2010-12-02 18:12:00	Clock Out		Normal record	Day	<input type="checkbox"/>	0
head office	8108		2010-12-03 08:56:00	Clock In		Normal record	Day	<input type="checkbox"/>	0
head office	8108		2010-12-03 18:12:00	Clock Out		Normal record	Day	<input type="checkbox"/>	0
head office	8108		2010-12-06 08:56:00	Clock In		Normal record	Day	<input type="checkbox"/>	0
head office	8108		2010-12-06 18:12:00	Clock Out		Normal record	Day	<input type="checkbox"/>	0
head office	8108		2010-12-07 08:56:00	Clock In		Normal record	Day	<input type="checkbox"/>	0
head office	8108		2010-12-07 18:12:00	Clock Out		Normal record	Day	<input type="checkbox"/>	0
head office	8108		2010-12-08 08:56:00	Clock In		Normal record	Day	<input type="checkbox"/>	0
head office	8108		2010-12-08 18:12:00	Clock Out		Normal record	Day	<input type="checkbox"/>	0
head office	8108		2010-12-09 08:56:00	Clock In		Normal record	Day	<input type="checkbox"/>	0
head office	8108		2010-12-09 18:24:00	Clock Out		Normal record	Day	<input type="checkbox"/>	0
head office	8108		2010-12-10 08:56:00	Clock In		Normal record	Day	<input type="checkbox"/>	0
head office	8108		2010-12-10 18:24:00	Clock Out		Normal record	Day	<input type="checkbox"/>	0
head office	8108		2010-12-13 08:56:00	Clock In		Normal record	Day	<input type="checkbox"/>	0
head office	8108		2010-12-13 18:28:00	Clock Out		Normal record	Day	<input type="checkbox"/>	0
head office	8108		2010-12-14 08:56:00	Clock In		Normal record	Day	<input type="checkbox"/>	0
head office	8108		2010-12-14 18:32:00	Clock Out		Normal record	Day	<input type="checkbox"/>	0
head office	8108		2010-12-15 08:56:00	Clock In		Normal record	Day	<input type="checkbox"/>	0
head office	8108		2010-12-15 18:56:00	Clock Out		Normal record	Day	<input type="checkbox"/>	0
head office	8108		2010-12-16 08:56:00	Clock In		Normal record	Day	<input type="checkbox"/>	0
head office	8108		2010-12-16 18:56:00	Clock Out		Normal record	Day	<input type="checkbox"/>	0
head office	8102		2010-12-01 09:00:00	Clock In		Normal record	Day	<input type="checkbox"/>	0

We will see such mistakes as “state mistake”, “invalid record”, “repeated record”, etc. are described. (If we will revise to write down, click the right key and springs the following menu):

Department	Employee No.	Name	Date Time	State	Operation	Exception Desc.	Timetable	Check	WorkCode
head office	8108		2010-12-01 08:56:00	Clock In		Normal record	Day	<input type="checkbox"/>	0
head office	8108		2010-12-01 18:12:00	Clock Out		Normal record	Day	<input type="checkbox"/>	0
head office	8108		2010-12-02 08:56:00	Clock In		Normal record	Day	<input type="checkbox"/>	0
head office	8108		2010-12-02 18:12:00	Clock Out		Normal record	Day	<input type="checkbox"/>	0
head office	8108		2010-12-03 08:56:00	Clock In		Normal record	Day	<input type="checkbox"/>	0
head office	8108		2010-12-03 18:12:00	Clock Out		Normal record	Day	<input type="checkbox"/>	0
head office	8108		2010-12-06 08:56:00	Clock In		Normal record	Day	<input type="checkbox"/>	0
head office	8108		2010-12-06 18:12:00	Clock Out		Normal record	Day	<input type="checkbox"/>	0
head office	8108		2010-12-07 08:56:00	Clock In		Normal record	Day	<input type="checkbox"/>	0
head office	8108		2010-12-07 18:12:00	Clock Out		Normal record	Day	<input type="checkbox"/>	0
head office	8108		2010-12-08 08:56:00	Clock In		Normal record	Day	<input type="checkbox"/>	0
head office	8108		2010-12-08 18:12:00	Clock Out		Normal record	Day	<input type="checkbox"/>	0
head office	8108		2010-12-09 08:56:00	Clock In		Normal record	Day	<input type="checkbox"/>	0
head office	8108		2010-12-09 18:24:00	Clock Out		Normal record	Day	<input type="checkbox"/>	0
head office	8108		2010-12-10 08:56:00	Clock In		Normal record	Day	<input type="checkbox"/>	0
head office	8108		2010-12-10 18:24:00	Clock Out		Normal record	Day	<input type="checkbox"/>	0
head office	8108		2010-12-13 08:56:00	Clock In		Normal record	Day	<input type="checkbox"/>	0
head office	8108		2010-12-13 18:28:00	Clock Out		Normal record	Day	<input type="checkbox"/>	0
head office	8108		2010-12-14 08:56:00	Clock In		Normal record	Day	<input type="checkbox"/>	0
head office	8108		2010-12-14 18:32:00	Clock Out		Normal record	Day	<input type="checkbox"/>	0
head office	8108		2010-12-15 08:56:00	Clock In		Normal record	Day	<input type="checkbox"/>	0
head office	8108		2010-12-15 18:56:00	Clock Out		Normal record	Day	<input type="checkbox"/>	0
head office	8108		2010-12-16 08:56:00	Clock In		Normal record	Day	<input type="checkbox"/>	0
head office	8108		2010-12-16 18:56:00	Clock Out		Normal record	Day	<input type="checkbox"/>	0
head office	8102		2010-12-01 09:00:00	Clock In		Normal record	Day	<input type="checkbox"/>	0

The definition of each option as follows:

[Export Data]: Export the data in the current attendance record list to a file in txt or xls format;

[Create report for current grid]: Generate report based on the data in the current

attendance record list for preview and print;

[Change state]: Change the selected attendance record to a new state.

Manually deal with the attendance record according to the practical situation;

[Delete selected]: Mark the record as manual deleting, deleting when save it;

[Cancel operation for selected]: Cancel revision to this record;

[Deal with and save]: You can save the records that have been treated. If you want to see the changed records, you can click [modified record log] in system menu;

[Filter the record]: If there are too many records, you can filter them, and keep down the corresponding record you want;

[Columns]: Define the fields displayed. Meanwhile, the modification will take effect and be saved;

[Show all columns]: Display all fields in [Columns];

Please note: We can manually modify the record as stated above to assure the veracity of the report according to the practical situation. If there is disoperation, the records can be recovered through [Modified Record Log] in [System].

Right Click in [Shift Exceptions] the following shortcut menu will pop up:

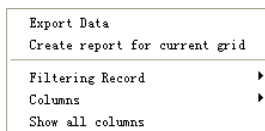

[Other Exceptions], [Calculated Items] the following shortcut menu will pop up:

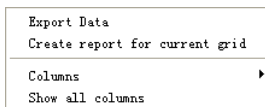

The operation is the same as stated above.

Report:

Click [Report] in pic5.6 and the following menu will pop up:

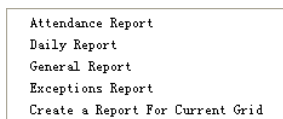

Pic5.7 Exception menu

[Attendance Report]: Calculate employee's attendance record;

Preview

100%

### Head office attendance record report

2009-04-01 To 2009-04-16

Administrator	Name	ID	Date	Time	Status
John Chen	0101	2009-04-01	07:23:05		Clock In
		2009-04-01	17:00:59		Clock Out
		2009-04-02	07:45:35		Clock In
		2009-04-02	17:05:16		Clock Out
		2009-04-03	07:52:12		Clock In
		2009-04-03	17:01:54		Clock Out
		2009-04-04	07:43:54		Clock In
		2009-04-06	07:38:36		Clock In
		2009-04-06	17:08:42		Clock Out
		2009-04-07	07:45:16		Clock In
		2009-04-07	17:14:20		Clock Out
		2009-04-08	07:08:12		Clock In
		2009-04-08	07:24:53		Clock In
		2009-04-08	17:20:05		Clock Out
		2009-04-09	07:49:52		Clock In
		2009-04-09	07:51:56		Clock In
2009-04-09	08:02:15		Clock In		
2009-04-09	17:11:24		Clock Out		
2009-04-10	07:45:19		Clock In		
2009-04-10	17:04:34		Clock Out		
2009-04-10	17:04:34		Clock Out		
2009-04-13	07:35:46		Clock In		
2009-04-13	17:27:06		Clock Out		
2009-04-14	07:06:12		Clock In		
2009-04-14	17:16:25		Clock Out		
2009-04-15	07:46:59		Clock In		
2009-04-15	17:08:53		Clock Out		
2009-04-16	08:00:59		Clock In		
Count: 27					
RID	King Jim	0103			
2009-04-01	07:23:05				Clock In
2009-04-01	17:00:59				Clock Out
2009-04-02	07:45:35				Clock In
2009-04-02	17:05:16				Clock Out
2009-04-03	07:52:12				Clock In
2009-04-03	17:01:54				Clock Out
2009-04-04	07:43:54				Clock In
2009-04-06	07:38:36				Clock In
2009-04-06	17:08:42				Clock Out
2009-04-07	07:45:16				Clock In
2009-04-07	17:14:20				Clock Out
2009-04-08	07:08:12				Clock In
2009-04-08	07:24:53				Clock In
2009-04-08	17:20:05				Clock Out
2009-04-09	07:49:52				Clock In
2009-04-09	07:51:56				Clock In
2009-04-09	08:02:15				Clock Out
2009-04-10	07:45:19				Clock In
2009-04-10	17:04:34				Clock Out
2009-04-10	17:04:34				Clock Out
2009-04-13	07:35:46				Clock In
2009-04-13	17:27:06				Clock Out
2009-04-14	07:06:12				Clock In
2009-04-14	17:16:25				Clock Out
2009-04-15	07:46:59				Clock In
2009-04-15	17:08:53				Clock Out
2009-04-16	08:00:59				Clock In
Count: 27					
RID	Mark Smith	0105			
2009-04-01	07:23:05				Clock In
2009-04-01	17:00:59				Clock Out
2009-04-02	07:45:35				Clock In
2009-04-02	17:05:16				Clock Out
2009-04-03	07:52:12				Clock In
2009-04-03	17:01:54				Clock Out
2009-04-04	07:43:54				Clock In
2009-04-06	07:38:36				Clock In
2009-04-06	17:08:42				Clock Out
2009-04-07	07:45:16				Clock In
2009-04-07	17:14:20				Clock Out
2009-04-08	07:08:12				Clock In
2009-04-08	07:24:53				Clock In
2009-04-08	17:20:05				Clock Out
2009-04-09	07:49:52				Clock In
2009-04-09	07:51:56				Clock In
2009-04-09	08:02:15				Clock Out
2009-04-10	07:45:19				Clock In
2009-04-10	17:04:34				Clock Out
2009-04-10	17:04:34				Clock Out
2009-04-13	07:35:46				Clock In
2009-04-13	17:27:06				Clock Out
2009-04-14	07:06:12				Clock In
2009-04-14	17:16:25				Clock Out
2009-04-15	07:46:59				Clock In
2009-04-15	17:08:53				Clock Out
2009-04-16	08:00:59				Clock In

Page 1/1

[Daily Report]: Calculate employee's daily attendance record;

Preview

100%

### head office Employee daily report

2010-12-01 To 2010-12-16

Name	No.	01	02	03	04	05	06	07	08	09	10	11	12	13	14	15	16	17	18	19	20	21	22	23	24	25	26	27	28	29	30	31	
head office																																	
Judy	0102	/	/	/	/	/	BL	/	/	/	/	/	/	/	/	/	/	/	/	/	/	/	/	/	/	/	/	/	/	/	/	/	/
Michael	0103	/	/	/	/	/	/	/	/	/	/	/	/	/	/	/	/	/	/	/	/	/	/	/	/	/	/	/	/	/	/	/	/
Liam	0108	/	/	/	/	/	/	/	/	/	/	/	/	/	/	/	/	/	/	/	/	/	/	/	/	/	/	/	/	/	/	/	/

Remark/Normal >Late <Early ~Absent [No C-In ]No C-Out Rest ~Overtime BLBusiness Leave LLeave

Tabling Admin 20101217 15:19:19 1

Page 1/1

[General Report]: Calculate all employee's attendance items such as "normal",

“actual”, “late”, “early”, “absent”, “overtime” etc;

**head office attendance stat. total report**

2010-12-01 To 2010-12-16

Name	Emplo No.	Duty Day	Actual Day	Absent Day	Late Minute	Early Minute	OT Hour	Free OT Hour	Out Minute	BL Day	Leave Day	N/A Times	N/Dut Times	W/Time Hour	AttRate %
<b>head office</b>															
Judy	9102		12	12					15						96%
Michael	9103		12	11	1										92%
Lizy	9108		12	12											100%
<b>Subtotal</b>	<b>3</b>		<b>36</b>	<b>25</b>	<b>1</b>				<b>15</b>						<b>96%</b>
<b>Total</b>	<b>3</b>		<b>36</b>	<b>25</b>	<b>1</b>				<b>15</b>						<b>96%</b>

TablingAdmin      2010-12-17 15:20:25      1

Page: 1/1

[Exceptions Report]: Calculate employee’s “out”, “overtime”, business leave/ personal leave” etc;

**head office attendance exceptions report**

2010-12-01 To 2010-12-16

Name	No.	Date & Time		Exception type	Work long	Remark
<b>head office</b>						
Judy	8102	2010-12-04 18:00:00	2010-12-05 09:00:00	Free overtime	15:00:00	
Judy	8102	2010-12-07 10:23:00	2010-12-07 13:56:00	Business leave	03:33:00	ttt

Page 1/1

[Create a Report for Current Grid]: Print preview of the current displayed grid.  
 For example: Attendance Report

Preview

↑ 100%

head office exceptions of shifts report

Department	Name	Employee No.	Date	Timetable	On Duty
head office	Judy	8102	2010-12-01	Day	2010-12-01 09:00
head office	Judy	8102	2010-12-02	Day	2010-12-02 09:00
head office	Judy	8102	2010-12-03	Day	2010-12-03 09:00
head office	Judy	8102	2010-12-06	Day	2010-12-06 09:00
head office	Judy	8102	2010-12-07	Day	2010-12-07 09:00
head office	Judy	8102	2010-12-08	Day	2010-12-08 09:00
head office	Judy	8102	2010-12-09	Day	2010-12-09 09:00
head office	Judy	8102	2010-12-10	Day	2010-12-10 09:00
head office	Judy	8102	2010-12-13	Day	2010-12-13 09:00
head office	Judy	8102	2010-12-14	Day	2010-12-14 09:00
head office	Judy	8102	2010-12-15	Day	2010-12-15 09:00
head office	Judy	8102	2010-12-16	Day	2010-12-16 09:00
head office	Michael	8103	2010-12-01	Day	2010-12-01 09:00
head office	Michael	8103	2010-12-02	Day	2010-12-02 09:00
head office	Michael	8103	2010-12-03	Day	2010-12-03 09:00
head office	Michael	8103	2010-12-06	Day	2010-12-06 09:00
head office	Michael	8103	2010-12-07	Day	2010-12-07 09:00
head office	Michael	8103	2010-12-08	Day	2010-12-08 09:00
head office	Michael	8103	2010-12-09	Day	2010-12-09 09:00
head office	Michael	8103	2010-12-10	Day	2010-12-10 09:00
head office	Michael	8103	2010-12-13	Day	2010-12-13 09:00
head office	Michael	8103	2010-12-14	Day	2010-12-14 09:00
head office	Michael	8103	2010-12-15	Day	2010-12-15 09:00
head office	Michael	8103	2010-12-16	Day	2010-12-16 09:00
head office	Lizzy	8108	2010-12-01	Day	2010-12-01 09:00
head office	Lizzy	8108	2010-12-02	Day	2010-12-02 09:00
head office	Lizzy	8108	2010-12-03	Day	2010-12-03 09:00

Page 1/3

Preview

↑ 100%

Off Duty	Clock In	Clock Out	Late	Early	OverTime
2010-12-01 17:30	2010-12-01 09:00:00	2010-12-01 18:00:00			
2010-12-02 17:30	2010-12-02 09:00:00	2010-12-02 18:00:00			
2010-12-03 17:30	2010-12-03 09:00:00	2010-12-03 18:00:00			
2010-12-06 17:30	2010-12-06 09:00:00	2010-12-06 18:00:00			
2010-12-07 17:30	2010-12-07 09:00:00	2010-12-07 18:00:00			
2010-12-08 17:30	2010-12-08 09:00:00	2010-12-08 18:00:00			
2010-12-09 17:30	2010-12-09 09:00:00	2010-12-09 18:00:00			
2010-12-10 17:30	2010-12-10 09:00:00	2010-12-10 18:00:00			
2010-12-13 17:30	2010-12-13 09:00:00	2010-12-13 18:00:00			
2010-12-14 17:30	2010-12-14 09:00:00	2010-12-14 18:00:00			
2010-12-15 17:30	2010-12-15 09:00:00	2010-12-15 18:00:00			
2010-12-16 17:30	2010-12-16 09:00:00	2010-12-16 18:00:00			
2010-12-01 17:30	2010-12-01 08:53:00	2010-12-01 18:03:36			
2010-12-02 17:30	2010-12-02 08:53:00	2010-12-02 18:03:36			
2010-12-03 17:30	2010-12-03 08:53:00	2010-12-03 18:03:36			
2010-12-06 17:30	2010-12-06 08:53:00	2010-12-06 18:03:36			
2010-12-07 17:30	2010-12-07 08:53:00	2010-12-07 18:03:36			
2010-12-08 17:30	2010-12-08 08:53:00	2010-12-08 18:03:36			
2010-12-09 17:30	2010-12-09 08:53:00	2010-12-09 18:03:36			
2010-12-10 17:30	2010-12-10 08:53:00	2010-12-10 18:03:36			
2010-12-13 17:30	2010-12-13 08:53:00	2010-12-13 18:03:36			
2010-12-14 17:30	2010-12-14 08:53:00	2010-12-14 18:01:35			
2010-12-15 17:30	2010-12-15 08:53:00	2010-12-15 18:05:52			
2010-12-16 17:30	2010-12-16 08:53:00	2010-12-16 17:59:52			
2010-12-01 17:30	2010-12-01 08:56:00	2010-12-01 18:12:00			
2010-12-02 17:30	2010-12-02 08:56:00	2010-12-02 18:12:00			
2010-12-03 17:30	2010-12-03 08:56:00	2010-12-03 18:12:00			
2010-12-06 17:30	2010-12-06 08:56:00	2010-12-06 18:12:00			
2010-12-07 17:30	2010-12-07 08:56:00	2010-12-07 18:12:00			
2010-12-08 17:30	2010-12-08 08:56:00	2010-12-08 18:12:00			
2010-12-09 17:30	2010-12-09 08:56:00	2010-12-09 18:12:00			
2010-12-10 17:30	2010-12-10 08:56:00	2010-12-10 18:12:00			

Page 2/3

Print Report:

Toolbar of report preview is as the following picture:





 100% Adjust the ratio of preview content;

 Open the existing report file;

Find the report file (\*.frp) to be opened, select it and click [Open] to see the report.

 Save report to file;

Select the directory to save the report to, enter the file name and click [Save] to complete the backup of the report for future check or copying to another computer for printing; extension file name is “\*.frp”.

 Print Report;

 Close Preview

Data Export:

In picture 5.6, click [Export] and the displayed data of grid in the current window will be exported to a file (\*.txt or \*.xls). It has the same function as [Export Data] when right clicking in each grid.

Exceptions dealt with:

In pic5.6, click [Exception] and the following menu will pop up:

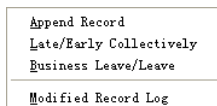

Click options one by one in the menu and the following modules will pop up respectively: [Append record], [Late/Early Collectively], [Business Leave/leave] and [Modified Record Log]. If the calculation result is incorrect for some employee, first, please check whether there is leave or forgetting Clock in or Clock out for this employee. If there is, please deal with the records through above menu. Please refer to the next chapter for more details.

## 5.5 Deal with Exceptions

Click [**Exception**] on the main menu, following springs:

Away On Business/Leave	Ctrl+L
Append Record	Ctrl+W
Append Record Collectively	
Dealing With Collectively Late/Early	

### 5.5.1 Away on Business/ Leave

When the employee can't punch in/out because of going out on business or asking for leave, in order to guarantee the exactness of the final statistics, we should make these settings through this function. Click [Away on Business/ Leave] in [Exception] menu, the following interface springs:

Department	Employee No.	Name	Beginning Time	Ending Time	Leave Type	Reason
------------	--------------	------	----------------	-------------	------------	--------

Deal with employee away on business / leave:

Click [Append], then select the proper department, employee ID, beginning time, ending time, leave type, and click save when ready.

Modification of employee away on business or leave:

Select the appointed employee whom you want to make this modification to, and click [Modify]. Then you can modify the relative information; click [Save] when ready.

Deletion of employee away on business or leave

Select the appointed employee and the relative information you want to make this deletion, and click [Delete].

### 5.5.2 Append Record

If an employee didn't punch in because of special reason, you can use this function to append the forgetting attendance record. Click [Append Record] in [Exception] menu, the following window Springs:

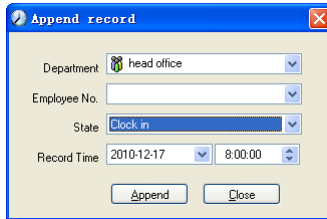

Select the relative items and click [Append] when ready.

### 5.5.3 Append Record Collectively

When part or all of the employees in a department did not punch in/out because of some reasons, please you can use this function to add punching in/out collectively, click [Exception]--[Append Record Collectively], following springs:

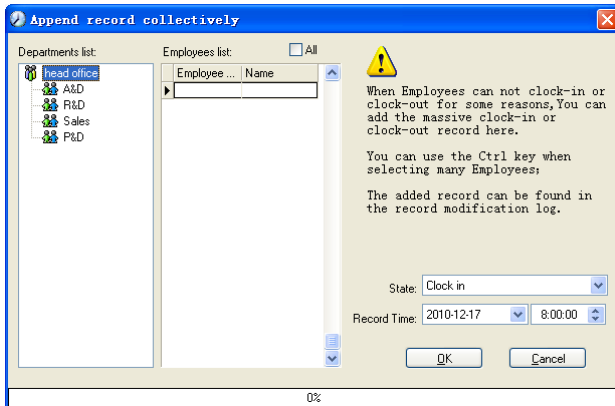

Select the department, thus the employees in the department will be listed in the employee list, select the employees whom you want to add records on to, then select record's state and time, then click [OK] to finish.

### 5.5.4 Dealing with Collectively Late / Leaving

When collectively coming late / leaving early takes place for some allowable

reasons, you can use this function. Click [Dealing with Collectively Late / Leaving] in [Exception] menu. The following springs:

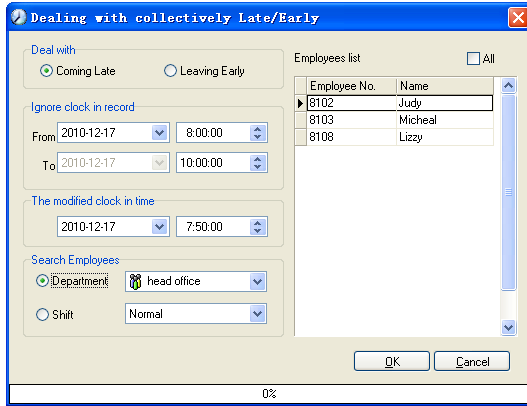

Steps as follows;

1. Click “Dealing with Collectively Late/Early”;
2. Select time range for “Ignore clock in record”;
3. Select the “The modified clock in time”
4. Search employee through department or shift;
5. Select employee;
6. Click [OK] to confirm.

## 5.6 Data Maintenance

Click [Data Maintenance] on the main menu, following springs:

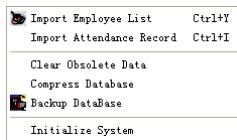

### 5.6.1 Import Employee List

Click [Import Employee List] in [Data Maintenance] menu. Pop up the following window:

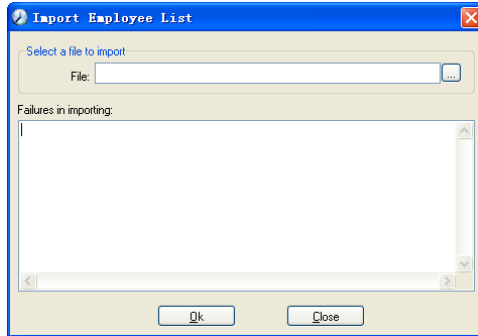

Click  to select the personnel list file for importing.

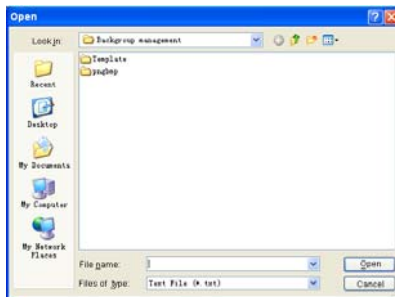

Select the right file which can be in \*.txt or MS Excel (\*.xls) formats, then click [open] to get back to above window, click [OK] to start!

The definition of (\*.txt) data format as follows:

This format of file only can import the employee info of “ID, Name, and department”;

The format of data must follow: Employee ID + Tab + Name + Tab + Department;

The information each employee takes one line, no blank line between one another.

This format of file can import the employee info includes: “Employee No., Name, Department, position, Employ Date, Telephone, Address, Sex, Language, Comment”; put those items on the head line and input the items by order, the order cannot be changed.

## 5.6.2 Import Attendance Record

Click [Import Attendance Record] in [Data Maintenance] menu, Springs the following window:

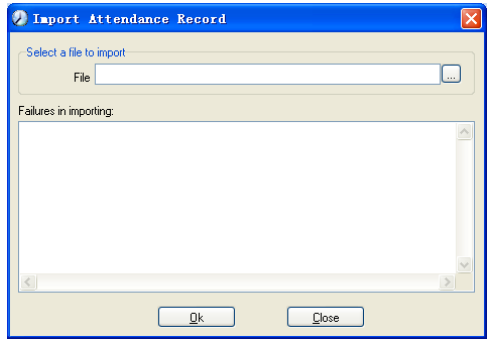

Click  to select the attendance record file for importing, and click [OK] to start.

### 5.6.3 Clear Obsolete Data

Click [Clear Obsolete Data] in [Data Maintenance] menu, springs the following window:



After your system is used for a long time, you will get a large number of obsolete data in the database. It ties up the hard disk space and influences your system operation speed. At this moment you can use this function to clear these useless data.

Select the ending date for your data clearing. And click [clear] to complete this operation, after the clearance, the system will prompt asking you to compress the database as following shows; select [OK] to finish. (Note: you can only clear the data of one month ago).

### 5.6.4 Compress Database

Click [Compress Database] in [Data Maintenance] menu to compress and repair the database

### 5.6.5 Backup Database

For ensuring the safety of data and recoverability, we advise you to back up the

database regularly. Click [Backup Database] in [Data Maintenance] menu, then select the route to back up the database. Click [Save] when ready.

Back up the database manually: Copy the Att2003.mdb from the installation directory to the route you want to back up the database, so if the system collapses, you just copy Att2003.mdb to installation directory over again after re-installation.

### 5.6.6 Initialize System

Click [Initialize System] in [Data Maintenance] to initialize the system. (Note: After the system is initialized, all information will be lost; the system will get back to the state when just installed. Please make sure that you want to initialize the system. )

## 5.7 External Program Management

Click [Device Management] on the main menu, following springs:

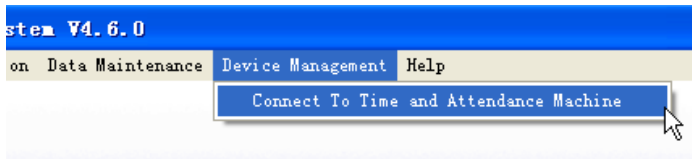

### 5.7.1 Connect to Communication management software

Click [Device Management]-[Connect to Time Attendance Machine], the system will prompt the communication interface between the software and the time attendance machine, control the current machine which connected with the computer, also can collect the records from the machine, upload and download employee information and fingerprint templates, or clear the old data on the attendance machine, modify the time on the machine. More details please reference the[Communication]chapter.

# Chapter6

## FAQ

Frequently asked questions and answers

e.g.: the FP has been enrolled but gets failure in identification;

No records found though identification have passed;

.....





## 6 FAQ

### 6.1 Fingerprint has been enrolled but gets failure in identification.

Reason	Solution
1. The fingerprint was not captured properly	Enroll the finger again.
2. The fingerprint is too dry or too wet with oil or cosmetics.	1. Touch the forehead to increase oily level of the finger; 2. Clean fingers with towel
3. The fingerprint has peeling or callus	Enroll other fingers with better quality
4. Latent fingerprint on the surface of sensor	Clean sensor surface(adhesive tapes recommended)

### 6.2 The machine can't be connected with PC

Reason	Solution
1. Cable not plugged firmly or cable hardware problem	Plug the cable firmly or change another cable
2. Not able to connect COM (wrong COM No.)	Enter the right COM No.

### 6.3 No records found though identification have passed

Reason	Solution
1. Unit power break for a long time(time turn to zero as default)	Synchronize the time
2. Minority staff fingerprint false accepted	Change another finger and enroll again
3. The records have not downloaded.	Downloading records in time.
4. Records have been full in machine.	Delete records in time.

### 6.4 The FP scanner is off and Employee can't identify.

Reason	Solution
--------	----------

1. Unit in sleeping status	Press the finger to active.
2. terminal is communication or has line's obstruction.	1. Cut the connection between terminal and pc. 2. Excludes the line's obstruction.
3. Fingerprint scanner abnormal.	Restart unit or change the fingerprint module

6.5 terminal beeps automatically when no one punches in/out

Reason	Solution
1. Direct sun light or too bright light	Avoid direct sun light or other bright light
2. Latent fingerprint on the surface of sensor	Clean sensor surface ( adhesive tapes recommended )

**Please note:** Should you have any other problems, please kindly email us the log files in zip or rar (The log files are in Log directory in the installation directory of the software)!

# Chapter7

# Appendix

The main theme of this chapter is the additional information of this T&A including access control cable connection

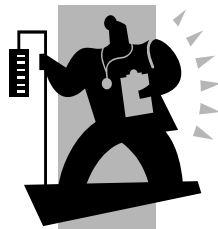

## 7 Appendix

### 7.1 Wiring Instruction ★

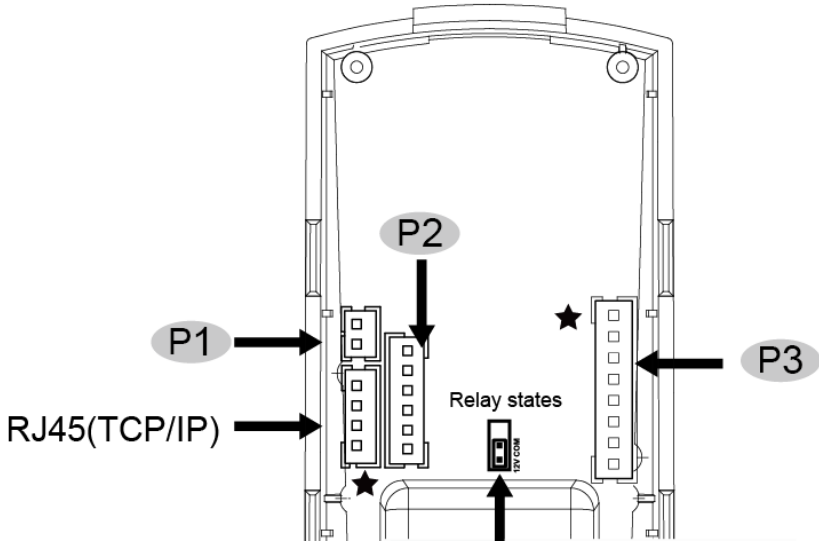

 12V COM	<b>P3</b> <table border="1"> <tr> <td>Relay</td> <td>5</td> <td>NO</td> </tr> <tr> <td></td> <td>6</td> <td>NC</td> </tr> <tr> <td></td> <td>7</td> <td>COM</td> </tr> </table>	Relay	5	NO		6	NC		7	COM	Select either 12 volt out on COM or voltage free contact.
Relay	5	NO									
	6	NC									
	7	COM									
 12V COM	<b>P3</b> <table border="1"> <tr> <td>Relay</td> <td>5</td> <td>DC12V</td> </tr> <tr> <td></td> <td>6</td> <td>DC12V</td> </tr> <tr> <td></td> <td>7</td> <td>COM</td> </tr> </table>	Relay	5	DC12V		6	DC12V		7	COM	
Relay	5	DC12V									
	6	DC12V									
	7	COM									

**P1**

Function	PIN	Cable Color	Description
Power	1	Red	DC12V
	2	Black	GND

## P2

Function	PIN	Cable Color	Description
Wiegand Output	1	Green	Wiegand DATA0 Output
	2	White	Wiegand DATA1 Output
	3	Black	GND
Green RS485	4	Yellow	RS485A
	5	Purple	RS485B
	6	Black	GND

## P3

Function	PIN	Cable Color	Description
Door Sensor	1	Purple	Trigger Input
Exit Button	2	Yellow	Trigger Input
	3	White	
	4	White	
Relay	5	Black	GND
	6	Green	COM
	7	Orange	NC
GND	8	Blue	NO

## 7.2 Wiring diagram★

### Access Control Reader & Power Supply:★

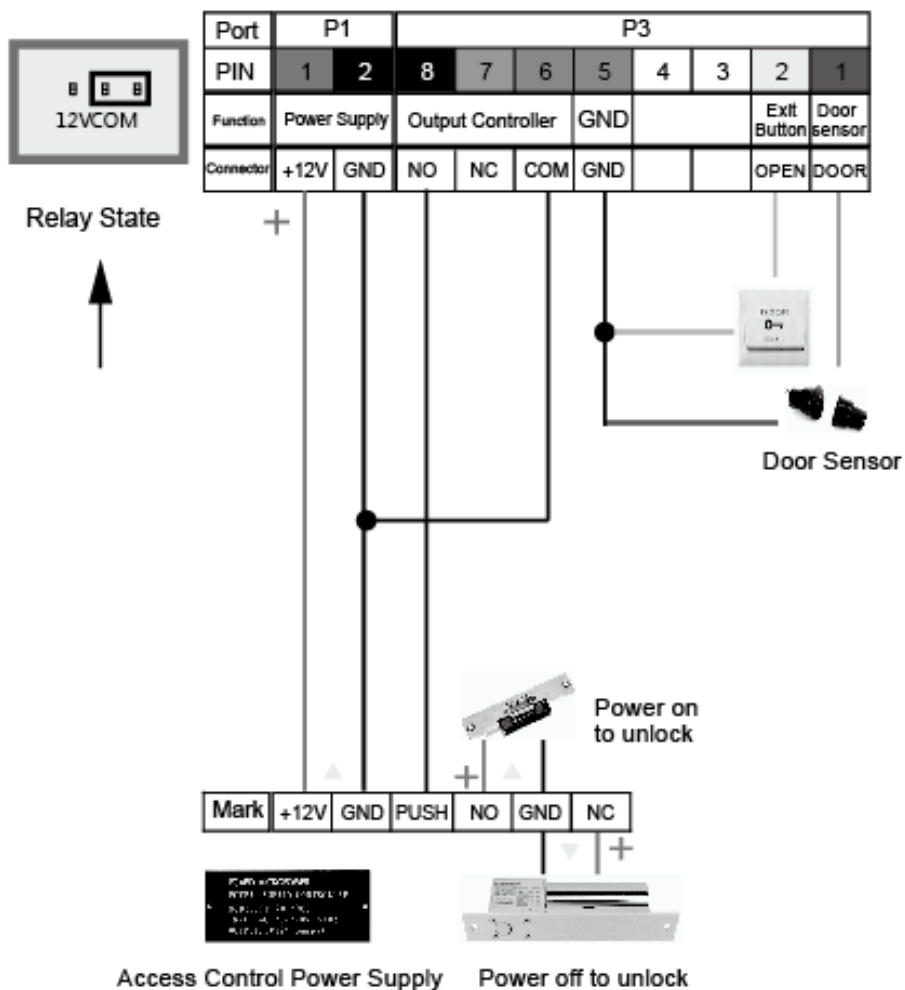

Access Control Reader & Switch Power Supply:★

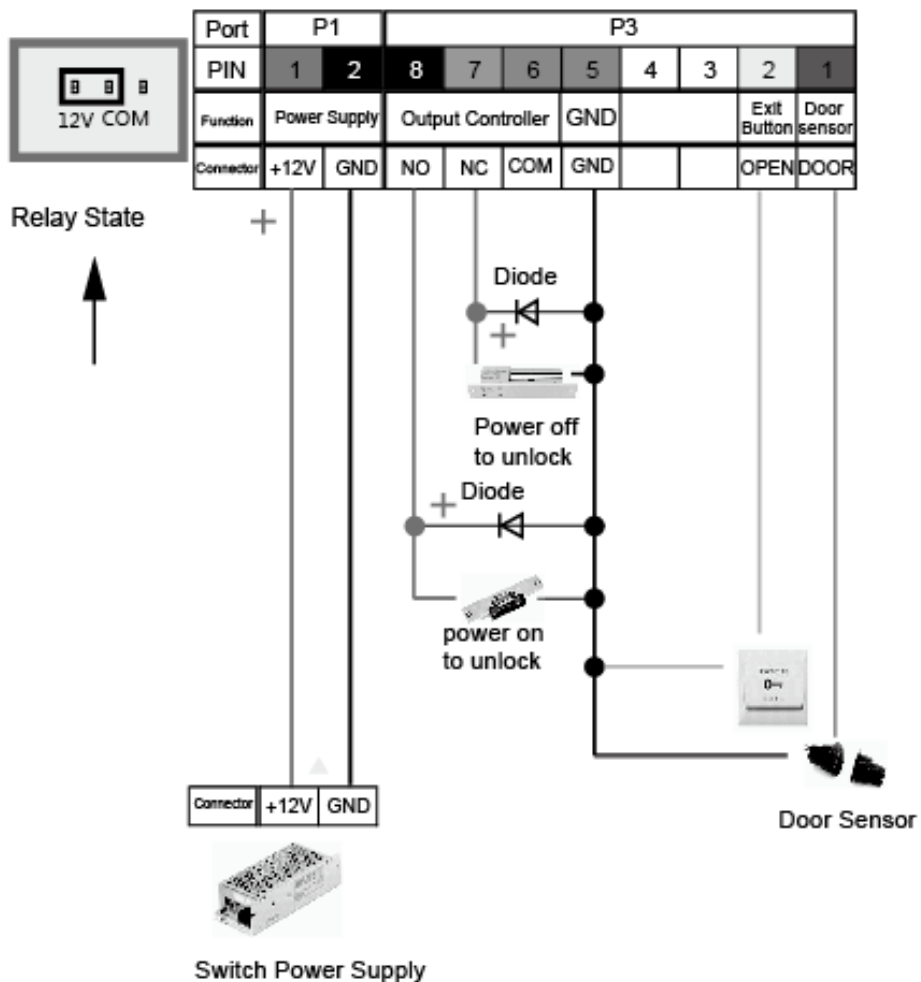

Access Control Reader & Controller:★

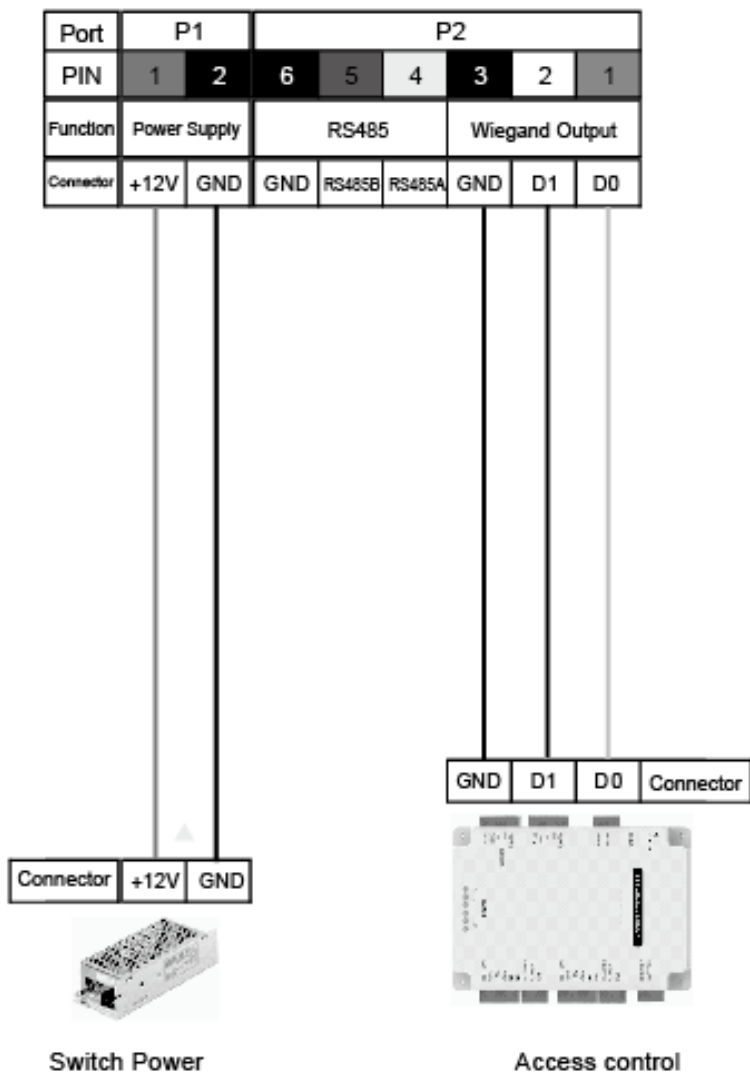



Communicate with PC : ★

