



Advanced Card Systems Ltd.
Card & Reader Technologies

ACR101

SIMicro (CCID)

Smart Card and Micro-SD Reader



Reference Manual



Table of Contents

1.0.	Introduction	3
2.0.	Features	4
3.0.	System Block Diagram	5
4.0.	Power Supply	6
4.1.	Status LED.....	6
5.0.	Smart Card Interface.....	7
5.1.	Smart Card Power Supply VCC (C1)	7
5.2.	Programming Voltage VPP (C6).....	7
5.3.	Card Type Selection	7
5.4.	Interface for Microcontroller-Based Cards.....	7
5.5.	Card Tearing Protection.....	7
6.0.	USB Interface.....	8
6.1.	Communication Parameters	8
6.2.	Endpoints	8
7.0.	Communication Protocol	9
7.1.	Command to the ACR101 (CCID)	10
7.1.1.	CCID Command Pipe Bulk-OUT Messages	10
7.1.2.	CCID Bulk-IN Messages	14
7.1.3.	Commands Accessed via PC_to_RDR_XfrBlock	16
7.2.	Mass Storage.....	17
Appendix A.	Supported Card Types.....	18
Appendix B.	Response Status Codes	19



1.0. Introduction

The ACR101 SIMicro (CCID) is a combination of a smart card reader and a Micro-SD card slot in a compact USB token which provides you with complete support for highly secure mobile applications. Furthermore, it has an embedded Mifare chip which allows the device to be used for contactless applications such as logical and physical access.

Designed to access SIM-sized smart cards and for data or application storage, it is perfect for GSM solutions, such as E-Government, E-Banking and E-Payment, Public Key Infrastructure, Network Security, GSM Management, VoIP, Secure Data Storage, Access Control, and Loyalty Program.



2.0. Features

- USB combo device – works as smart card reader and mass storage
- USB 2.0 Hi-Speed Interface
- Bus-powered – no need for separate power supply or battery
- Plug-and-play – CCID support brings utmost compatibility and mobility
- With extractable USB cable and keychain loop
- Smart card reader:
 - Supports plug-in (SIM-sized) cards
 - Supports ISO 7816 Classes A, B and C (5 V, 3 V, 1.8 V) cards
 - Reads and writes onto all microprocessor cards with the T=0, T=1 protocol
 - Supports memory cards
 - Supports Spec 11.11-compliant GSM cards
 - Short circuit protection
- Memory Card Support:
 - Supports Micro-SD cards with up to 8 GB memory
- Contactless Feature
 - Features embedded Mifare 1K Chip
- Compliant with the following international standards:
 - PC/SC
 - CCID
 - Microsoft WHQL
 - CE
 - FCC
 - VCCI
 - RoHS

3.0. System Block Diagram

The USB Hub Controller is the communication interface between the PC and the MCU of the smart card and flash memory via USB port connection. The 1-GB flash memory is available for the end-user to use as storage. In Windows Explorer, the device is detected as a removable disk. The ACR101 (CCID) is powered from the USB port without other external power supply.

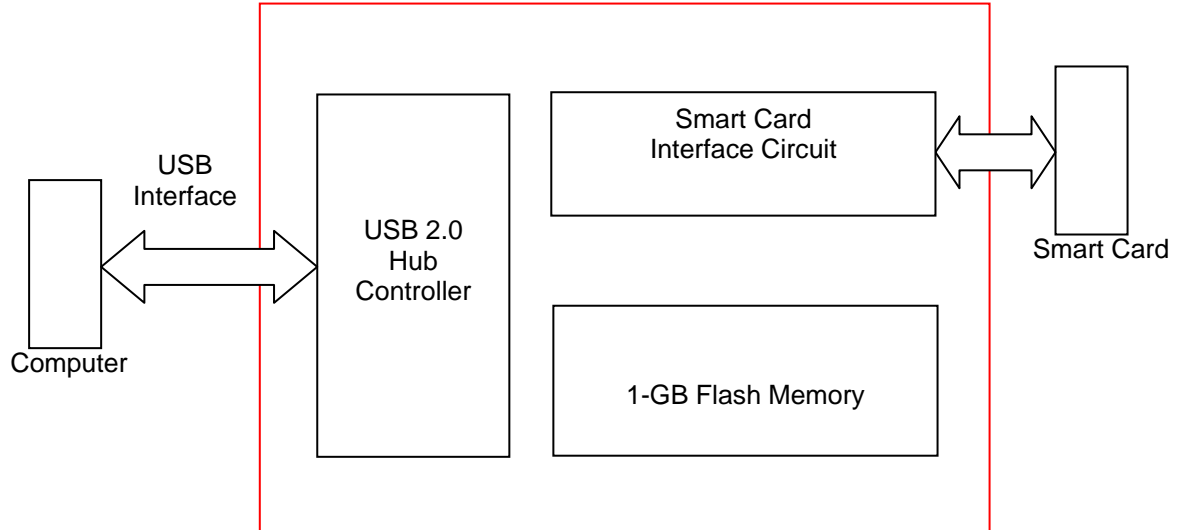

Figure 1: ACR101 System Block Diagram



4.0. Power Supply

The ACR101 (CCID) requires a voltage of 5V DC, 100mA regulated power supply. It gets the power supply from the PC.

4.1. Status LED

Bicolor LED on the front of the reader indicates the activation status of the smart card and flash memory interface.

GREEN LED:

Flashing slowly (turns on 200ms for every 2 seconds)

Indicates smart card interface part is powered up and in the standby state. Either the smart card has not been inserted or the smart card has not been powered up (if it is inserted).

Lighting up

Indicates power supply to the smart card is switched on, i.e., the smart card is activated.

RED LED:

Lighting up

Indicates a communication between ACR101 (CCID) and flash memory.



5.0. Smart Card Interface

The interface between the ACR101 (CCID) and the inserted smart card follows the specifications of ISO7816-3.

5.1. Smart Card Power Supply VCC (C1)

The current consumption of the inserted card must not be higher than 50mA.

5.2. Programming Voltage VPP (C6)

According to ISO 7816-3, the smart card contact C6 (VPP) supplies the programming voltage to the smart card. Since all common smart cards in the market are EEPROM based and do not require the provision of an external programming voltage, the contact C6 (VPP) has been implemented as a normal control signal in the ACR101 (CCID). The electrical specifications of this contact are identical to those of the signal RST (at contact C2).

5.3. Card Type Selection

The controlling PC has to select the card type always, through the proper command sent to the ACR101 (CCID) prior to activating the inserted card. This includes both the memory cards and MCU-based cards. For MCU-based cards the reader allows to select the preferred protocol, T=0 or T=1. However, this selection is only accepted and carried out by the reader through the PPS when the card inserted in the reader supports both protocol types. Whenever an MCU-based card supports only one protocol type, T=0 or T=1, the reader automatically uses that protocol type, regardless of the protocol type selected by the application.

5.4. Interface for Microcontroller-Based Cards

For microcontroller-based smart cards, only the contacts C1 (VCC), C2 (RST), C3 (CLK), C5 (GND) and C7 (I/O) are used. A frequency of 4 MHz is applied to the CLK signal (C3).

5.5. Card Tearing Protection

The ACR101 (CCID) provides a mechanism to protect the inserted card when it is suddenly withdrawn while it is powered up. The power supply to the card and the signal lines between the ACR101 (CCID) and the card are immediately deactivated when the card is being removed. As a general rule, however, to avoid any electrical damage, **a card should only be removed from the reader while it is powered down.**

Note: The ACR101 (CCID) never switches on the power supply to the inserted card by itself. This must be done by the controlling computer through the proper command sent to the reader.



6.0. USB Interface

The ACR101 (CCID) is connected to a computer through a USB following the USB standard.

6.1. Communication Parameters

The ACR101 (CCID) is connected to a computer through USB as specified in the USB Specification. The ACR101 (CCID) is working in high speed mode, i.e. 480 Mbps, for the flash memory.

Pin	Signal	Function
1	V _{BUS}	+5V power supply for the reader
2	D-	Differential signal transmits data between ACR101 (CCID) and PC.
3	D+	Differential signal transmits data between ACR101 (CCID) and PC.
4	GND	Reference voltage level for power supply

6.2. Endpoints

The ACR101 (CCID) uses the following endpoints to communicate with the host computer:

- Control Endpoint 0** For setup and control purposes
- Bulk OUT Endpoint 1** For the command to be sent from host to Mass Storage Interface (data packet size is 64 bytes)
- Bulk IN Endpoint 1** For response to be sent from Mass Storage Interface to host (data packet size is 64 bytes)
- Bulk OUT Endpoint 2** For command to be sent from host to CCID Interface (data packet size is 16 bytes)
- Bulk IN Endpoint 2** For response to be sent from CCID Interface to host (data packet size is 16 bytes)



7.0. Communication Protocol

ACR101 (CCID) interfaces with the host via USB connection. It is a compounded device consisting of two interfaces: Chip Card Interface Device and Mass Storage.

The ACR101 (CCID) Smart Card Interface shares the same core as the smart card interface of the ACR38 CCID. The Smart Card Interface will be identified as “ACR38-112c” once the reader FW is obtained. (The command for this will be discussed later on). CCID covers all the protocols required for operating smart cards and PIN.

The configurations and usage of USB endpoints on ACR101 (CCID) Smart Card Interface shall follow CCID Section 3. An overview is summarized below:

1. *Control Commands* are sent on control pipe (default pipe). These include class-specific requests and USB standard requests. Commands that are sent on the default pipe report information back to the host on the default pipe.
2. CCID Events are sent on the interrupt pipe.
3. CCID Commands are sent on *BULK-OUT* endpoint. Each command sent to smart card reader has an associated ending response. Some commands can also have intermediate responses.
4. CCID Responses are sent on *BULK-IN* endpoint. All commands sent to the smart card reader have to be sent synchronously. (i.e. *bMaxCCIDBusySlots* is equal to 1)

The supported CCID features by ACR101 (CCID) smart card interface are indicated in its Class Descriptor:

Offset	Field	Size	Value	Description
0	bLength	1	36h	Size of this descriptor, in bytes.
1	bDescriptorType	1	21h	CCID Functional Descriptor type.
2	bcdCCID	2	0100h	CCID Specification Release Number in Binary-Coded decimal.
4	bMaxSlotIndex	1	00h	One slot is available
5	bVoltageSupport	1	07h	The Smart card reader can supply 1.8V, 3.0V and 5.0V to its slot.
6	dwProtocols	4	00000003h	The Smart card reader supports T=0 and T=1 Protocol
10	dwDefaultClock	4	00000FA0h	Default ICC clock frequency is 4MHz
14	dwMaximumClock	4	00000FA0h	Maximum supported ICC clock frequency is 4MHz
18	bNumClockSupported	1	00h	Does not support manual setting of clock frequency
19	dwDataRate	4	00002A00h	Default ICC I/O data rate is 10752 bps
23	dwMaxDataRate	4	0001F808h	Maximum supported ICC I/O data rate is 344 kbps
27	bNumDataRatesSupported	1	00h	Does not support manual setting of data rates
28	dwMaxIFSD	4	00000Feh	Maximum IFSD supported by the smart card reader for protocol T=1 is 254



Offset	Field	Size	Value	Description
32	dwSynchProtocols	4	00000000h	The Smart card reader does not support synchronous card
36	dwMechanical	4	00000000h	The Smart card reader does not support special mechanical characteristics
40	dwFeatures	4	00010030h	The Smart card reader supports the following features: <ul style="list-style-type: none"> • Automatic ICC clock frequency change according to parameters • Automatic baud rate change according to frequency and FI,DI parameters • TPDU level exchange with the smart card reader
44	dwMaxCCIDMessageLength	4	0000010Fh	Maximum message length accepted by the smart card reader is 271 bytes
48	bClassGetResponse	1	00h	Insignificant for TPDU level exchanges
49	bClassEnvelope	1	00h	Insignificant for TPDU level exchanges
50	wLCDLayout	2	0000h	No LCD
52	bPINSupport	1	00h	No PIN Verification
53	bMaxCCIDBusySlots	1	01h	Only 1 slot can be simultaneously busy

7.1. Command to the ACR101 (CCID)

In a normal operation, the ACR101 (CCID) acts as a slave device with regards to the communication between a computer and the reader. The communication is carried out in the form of successive command-response exchanges. The computer transmits a command to the reader and receives a response from the reader after the command has been executed. A new command can be transmitted to the ACR101 (CCID) only after the response to the previous command has been received.

There are two cases where the reader transmits data without having received a command from the computer, namely, the `Reset Message` of the reader and the `Card Status Message`.

7.1.1. CCID Command Pipe Bulk-OUT Messages

The ACR101 (CCID) shall follow the CCID Bulk-OUT Messages as specified in CCID section 4. In addition, this specification defines some extended commands for operating additional features. This section lists the CCID Bulk-OUT Messages to be supported by ACR101 (CCID).

7.1.1.1. PC_to_RDR_IccPowerOn

Activate the card slot and return ATR from the card.



Offset	Field	Size	Value	Description
0	bMessageType	1	62h	
1	dwLength	4	00000000h	Size of extra bytes of this message
2	bSlot	1		Identifies the slot number for this command
5	bSeq	1		Sequence number for command
6	bPowerSelect	1		Voltage that is applied to the ICC 00h – Automatic Voltage Selection 01h – 5 volts 02h – 3 volts
7	abRFU	2		Reserved for future use

The response to this message is the RDR_to_PC_DataBlock message and the data returned is the Answer To Reset (ATR) data.

7.1.1.2. PC_to_RDR_IccPowerOff

Deactivate the card slot.

Offset	Field	Size	Value	Description
0	bMessageType	1	63h	
1	dwLength	4	00000000h	Size of extra bytes of this message
5	bSlot	1		Identifies the slot number for this command
6	bSeq	1		Sequence number for command
7	abRFU	3		Reserved for future use

The response to this message is the RDR_to_PC_SlotStatus message.

7.1.1.3. PC_to_RDR_GetSlotStatus

Get current status of the slot.

Offset	Field	Size	Value	Description
0	bMessageType	1	65h	
1	dwLength	4	00000000h	Size of extra bytes of this message
5	bSlot	1		Identifies the slot number for this command
6	bSeq	1		Sequence number for command
7	abRFU	3		Reserved for future use

The response to this message is the RDR_to_PC_SlotStatus message.



7.1.1.4. PC_to_RDR_XfrBlock

Transfer data block to the ICC.

Offset	Field	Size	Value	Description
0	bMessageType	1	6Fh	
1	dwLength	4		Size of abData field of this message
5	bSlot	1		Identifies the slot number for this command
6	bSeq	1		Sequence number for command
7	bBWI	1		Used to extend the CCIDs Block Waiting Timeout for this current transfer. The CCID will timeout the block after "this number multiplied by the Block Waiting Time" has expired.
8	wLevelParameter	2	0000h	RFU (TPDU exchange level)
10	abData	Byte array		Data block sent to the CCID. Data is sent "as is" to the ICC (TPDU exchange level)

The response to this message is the RDR_to_PC_DataBlock message.

7.1.1.5. PC_to_RDR_GetParameters

Get slot parameters.

Offset	Field	Size	Value	Description
0	bMessageType	1	6Ch	
1	DwLength	4	00000000h	Size of extra bytes of this message
5	BSlot	1		Identifies the slot number for this command
6	BSeq	1		Sequence number for command
7	AbRFU	3		Reserved for future use

The response to this message is the RDR_to_PC_Parameters message.

7.1.1.6. PC_to_RDR_ResetParameters

Reset slot parameters to default value.

Offset	Field	Size	Value	Description
0	bMessageType	1	6Dh	
1	DwLength	4	00000000h	Size of extra bytes of this message
5	BSlot	1		Identifies the slot number for this command
6	BSeq	1		Sequence number for command
7	AbRFU	3		Reserved for future use

The response to this message is the RDR_to_PC_Parameters message.



7.1.1.7. PC_to_RDR_SetParameters

Set slot parameters.

Offset	Field	Size	Value	Description
0	bMessageType	1	61h	
1	dwLength	4		Size of extra bytes of this message
5	bSlot	1		Identifies the slot number for this command
6	bSeq	1		Sequence number for command
7	bProtocolNum	1		Specifies what protocol data structure follows. 00h = Structure for protocol T=0 01h = Structure for protocol T=1 The following values are reserved for future use. 80h = Structure for 2-wire protocol 81h = Structure for 3-wire protocol 82h = Structure for I2C protocol
8	abRFU	2		Reserved for future use
10	abProtocolData Structure	Byte array		Protocol Data Structure

Protocol Data Structure for Protocol T=0 (dwLength=00000005h)

Offset	Field	Size	Value	Description
10	bmFindexDindex	1		B7-4 – FI – Index into the table 7 in ISO/IEC 7816-3:1997 selecting a clock rate conversion factor B3-0 – DI - Index into the table 8 in ISO/IEC 7816-3:1997 selecting a baud rate conversion factor
11	bmTCCCKST0	1		B0 – 0b, B7-2 – 000000b B1 – Convention used (b1=0 for direct, b1=1 for inverse) Note: The CCID ignores this bit.
12	bGuardTimeT0	1		Extra Guardtime between two characters. Add 0 to 254 etu to the normal guardtime of 12 etu. FFh is the same as 00h.
13	bWaitingIntegerT0	1		WI for T=0 used to define WWT
14	bClockStop	1		ICC Clock Stop Support 00h = Stopping the Clock is not allowed 01h = Stop with Clock signal Low 02h = Stop with Clock signal High 03h = Stop with Clock either High or Low



Protocol Data Structure for Protocol T=1 (dwLength=00000007h)

Offset	Field	Size	Value	Description
10	bMFindexDindex	1		B7-4 – FI – Index into the table 7 in ISO/IEC 7816-3:1997 selecting a clock rate conversion factor B3-0 – DI - Index into the table 8 in ISO/IEC 7816-3:1997 selecting a baud rate conversion factor
11	BmTCCKST1	1		B7-2 – 000100b B0 – Checksum type (b0=0 for LRC, b0=1 for CRC) B1 – Convention used (b1=0 for direct, b1=1 for inverse) Note: The CCID ignores this bit.
12	BGuardTimeT1	1		Extra Guardtime (0 to 254 etu between two characters). If value is FFh, then guardtime is reduced by 1 etu.
13	BwaitingIntegerT1	1		B7-4 = BWI values 0-9 valid B3-0 = CWI values 0-Fh valid
14	bClockStop	1		ICC Clock Stop Support 00h = Stopping the Clock is not allowed 01h = Stop with Clock signal Low 02h = Stop with Clock signal High 03h = Stop with Clock either High or Low
15	bIFSC	1		Size of negotiated IFSC
16	bNadValue	1	00h	Only support NAD = 00h

The response to this message is the RDR_to_PC_Parameters message.

7.1.2. CCID Bulk-IN Messages

The Bulk-IN messages are used in response to the Bulk-OUT messages. ACR101 (CCID) shall follow the CCID Bulk-IN Messages as specified in section 4. This section lists the CCID Bulk-IN Messages to be supported by ACR101 (CCID).

7.1.2.1. RDR_to_PC_DataBlock

This message is sent by the smart card reader in response to PC_to_RDR_IccPowerOn, PC_to_RDR_XfrBlock and PC_to_RDR_Secure messages.

Offset	Field	Size	Value	Description
0	bMessageType	1	80h	Indicates that a data block is being sent from the CCID
1	dwLength	4		Size of extra bytes of this message
5	bSlot	1		Same value as in Bulk-OUT message
6	bSeq	1		Same value as in Bulk-OUT message
7	bStatus	1		Slot status register as defined in CCID section 4.2.1
8	bError	1		Slot error register as defined in CCID section 4.2.1 and this specification section 5.2.8
9	bChainParameter	1	00h	RFU (TPDU exchange level)
10	abData	Byte array		This field contains the data returned by the CCID



7.1.2.2. RDR_to_PC_SlotStatus

This message is sent by the smart card reader in response to PC_to_RDR_IccPowerOff, PC_to_RDR_GetSlotStatus, PC_to_RDR_Abort messages and Class specific ABORT request.

Offset	Field	Size	Value	Description
0	bMessageType	1	81h	
1	dwLength	4	00000000h	Size of extra bytes of this message
5	bSlot	1		Same value as in Bulk-OUT message
6	bSeq	1		Same value as in Bulk-OUT message
7	bStatus	1		Slot status register as defined in CCID section 4.2.1
8	bError	1		Slot error register as defined in CCID section 4.2.1 and this specification section 5.2.8
9	bClockStatus	1		value = 00h Clock running 01h Clock stopped in state L 02h Clock stopped in state H 03h Clock stopped in an unknown state All other values are RFU.



7.1.2.3. RDR_to_PC_Parameters

This message is sent by the smart card reader in response to PC_to_RDR_GetParameters, PC_to_RDR_ResetParameters and PC_to_RDR_SetParameters messages.

Offset	Field	Size	Value	Description
0	bMessageType	1	82h	
1	dwLength	4		Size of extra bytes of this message
5	bSlot	1		Same value as in Bulk-OUT message
6	bSeq	1		Same value as in Bulk-OUT message
7	bStatus	1		Slot status register as defined in CCID section 4.2.1
8	bError	1		Slot error register as defined in CCID section 4.2.1 and this specification section 5.2.8
9	bProtocolNum	1		Specifies what protocol data structure follows. 00h = Structure for protocol T=0 01h = Structure for protocol T=1 The following values are reserved for future use. 80h = Structure for 2-wire protocol 81h = Structure for 3-wire protocol 82h = Structure for I2C protocol
10	abProtocolData Structure	Byte array		Protocol Data Structure as summarized in section 5.2.3.

7.1.3. Commands Accessed via PC_to_RDR_XfrBlock

7.1.3.1. GET_READER_INFORMATION

This command returns relevant information about the particular smart card reader model and the current operating status such as the firmware revision number, the maximum data length of a command and response, the supported card types, and whether a card is inserted and powered up or not.

Note: This command can only be used after the logical smart card reader communication has been established using the SCardConnect() API. For details of SCardConnect() API, please refer to PC/SC specification.

Pseudo-APDU				
CLA	INS	P1	P2	Lc
FF _H	09 _H	00 _H	00 _H	10 _H

Command format (abData field in the PC_to_RDR_XfrBlock)

FIRMWARE	MAX_C	MAX_R	C_TYPE	C_SEL	C_STAT

Response data format (abData field in the RDR_to_PC_DataBlock)



- FIRMWARE** 10 bytes data for firmware version
- MAX_C** The maximum number of command data bytes.
- MAX_R** The maximum number of data bytes that can be requested to be transmitted in a response.
- C_TYPE** The card types supported by the smart card reader. This data field is a bitmap with each bit representing a particular card type. A bit set to '1' means the corresponding card type is supported by the reader and can be selected with the *SELECT_CARD_TYPE* command. The bit assignment is as follows:

Byte	1								2							
card type	F	E	D	C	B	A	9	8	7	6	5	4	3	2	1	0

See Appendix A.1 for the correspondence between these bits and the respective card types.

- C_SEL** The currently selected card type. A value of 00_H means that no card type has been selected.
- C_STAT** Indicates whether a card is physically inserted in the reader and whether the card is powered up:
 - 00_H: no card inserted
 - 01_H: card inserted, not powered up
 - 03_H: card powered up

7.2. Mass Storage

Mass Storage Device Class specifies all the protocols required for data transaction between Host (computer) and storage devices. The configurations and usage of USB endpoints on ACR101 (CCID) shall follow Mass Storage Class Bulk-Only Transport in Section 3 (Protocol Code) of the USB Mass Storage Device Specification. This document is available at: www.usb.org.

An overview of this specification is summarized below:

1. *Control Commands* are sent on control pipe (default pipe). It is shared with the CCID interface.
2. *Data-Out Command* Protocol uses the BULK-OUT endpoint to transfer data from the host to the device.
3. *Data-In Command* Protocol uses the BULK-IN endpoint to transfer data from the device or to return status about the device.



Appendix A. Supported Card Types

The following table is a list of the card types returned by GET_READER_INFORMATION corresponding with the respective card type code:

Card type code	Card Type
00 _H	Auto-select T=0 or T=1 communication protocol
01 _H	I2C memory card (1k, 2k, 4k, 8k and 16k bits)
02 _H	I2C memory card (32k, 64k, 128k, 256k, 512k and 1024k bits)
03 _H	Atmel AT88SC153 secure memory card
04 _H	Atmel AT88SC1608 secure memory card
05 _H	Infineon SLE4418 and SLE4428
06 _H	Infineon SLE4432 and SLE4442
07 _H	Infineon SLE4406, SLE4436 and SLE5536
08 _H	Infineon SLE4404
09 _H	Atmel AT88SC101, AT88SC102 and AT88SC1003
0C _H	MCU-based cards with T=0 communication protocol
0D _H	MCU-based cards with T=1 communication protocol



Appendix B. Response Status Codes

The following table is a list of the error codes that may be returned by the ACR38:

Error Code	Status
FF _H	SLOTERROR_CMD_ABORTED
FE _H	SLOTERROR_ICC_MUTE
FD _H	SLOTERROR_XFR_PARITY_ERROR
FC _H	SLOTERROR_XFR_OVERRUN
FB _H	SLOTERROR_HW_ERROR
F8 _H	SLOTERROR_BAD_ATR_TS
F7 _H	SLOTERROR_BAD_ATR_TCK
F6 _H	SLOTERROR_ICC_PROTOCOL_NOT_SUPPORTED
F5 _H	SLOTERROR_ICC_CLASS_NOT_SUPPORTED
F4 _H	SLOTERROR_PROCEDURE_BYTE_CONFLICE
F3 _H	SLOTERROR_DEACTIVATED_PROTOCOL
F2 _H	SLOTERROR_BUSY_WITH_AUTO_SEQUENCE
E0 _H	SLOTERROR_CMD_SLOT_BUSY